



International Electronics Manufacturing Initiative

The iNEMI Roadmap

Bob Pfahl, Vice President of Operations

2006 ITRS Public Conference
July 12, 2006; San Francisco

- **The iNEMI Process**
 - iNEMI Mission
 - Roadmap Methodology
 - iNEMI Outputs
- **Relationship to ITRS**
 - Organization and Structure
- **The iNEMI Roadmaps**
 - 2004 Roadmap Demographics, Size, Results
 - 2007 Roadmap Structure, Partners
 - The 2007 Roadmap Schedule
- **Conclusions from the 2004 Roadmap/2005 Research Priorities**
- **Concluding Thoughts**

iNEMI mission is dedicated to providing leadership for the global electronics manufacturing supply chain for the benefit of its member companies and the industry.

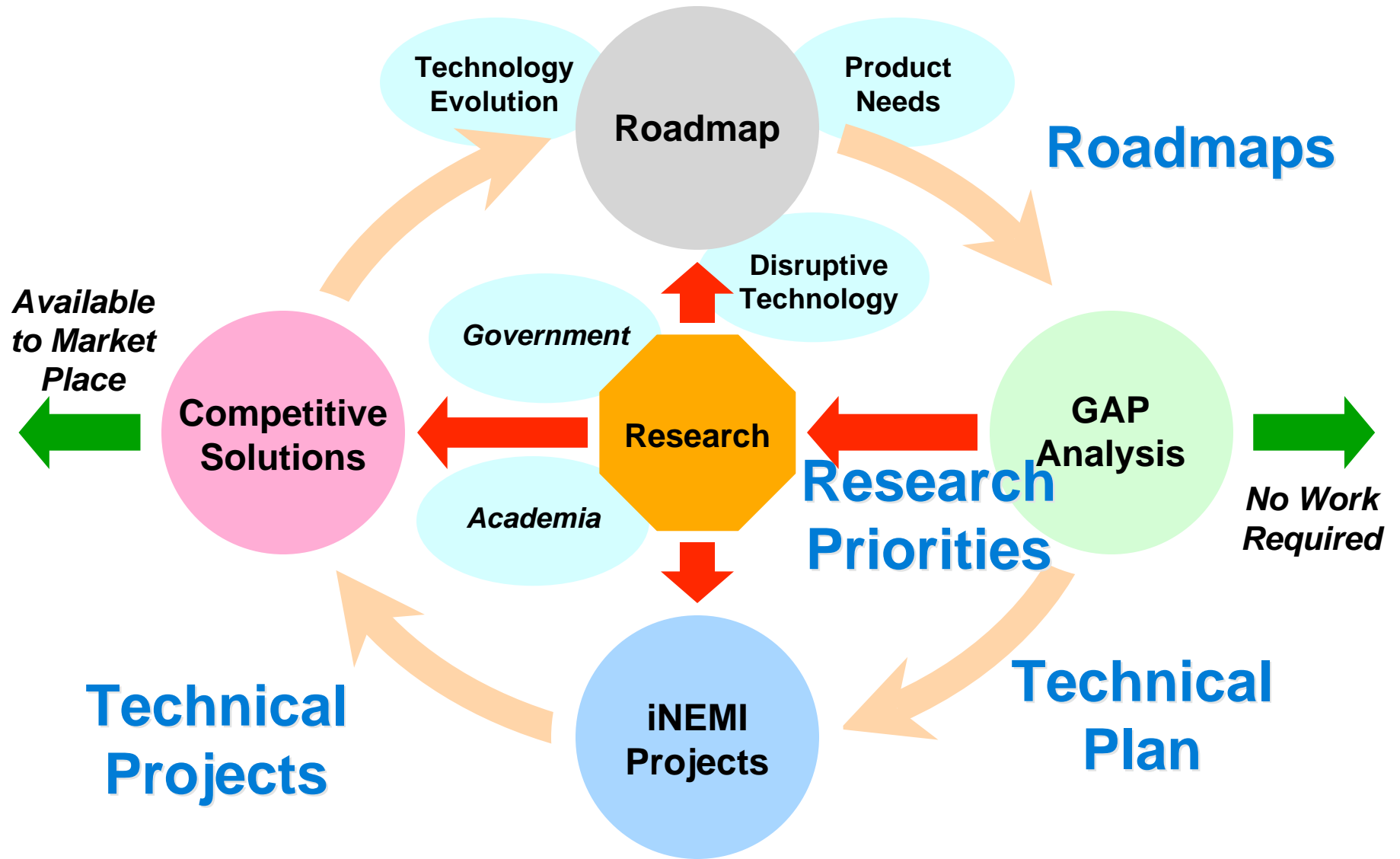

- **Advances in Semiconductor Technology continue to enable exciting new products for the Electronics Industry.**
- **International Technology Roadmap for Semiconductors (ITRS) is the world-wide authority for the Semiconductor Industry.**
- **iNEMI has a close working relationship with ITRS to ensure that our Systems view of the industry has the appropriate input for:**
 - **Semiconductor Technology**
 - **Packaging Technology**
- **In return, iNEMI PEGs provide systems input for ITRS.**

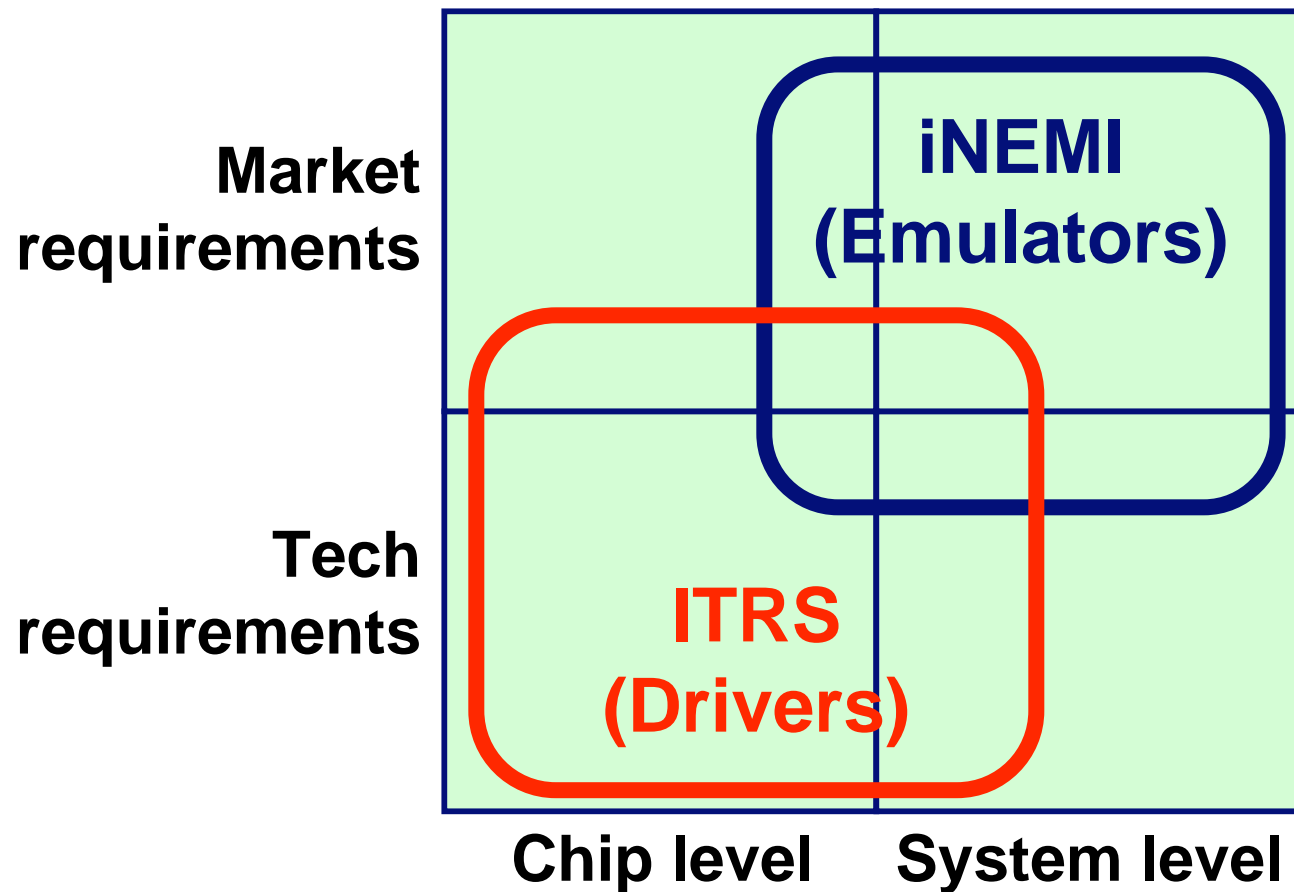

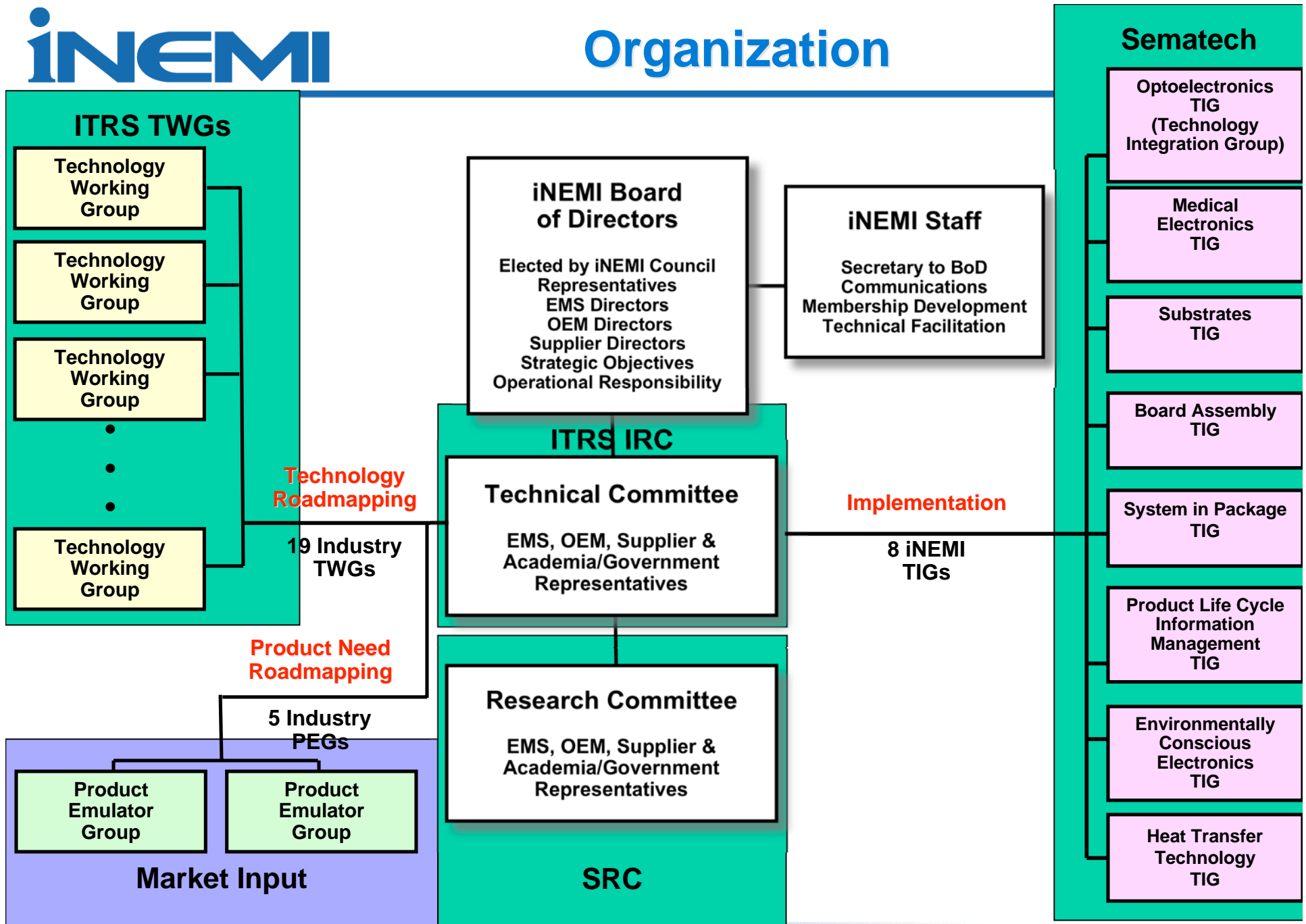

- **2007 Roadmap cycle will include 5 Product Emulator Chapters**
- **A product emulator is defined as an abstract representation of a product to allow companies to share needs without sharing proprietary product information**
- **Each chapter sets OEM requirements over the next 10 years**
- **Requirements are presented as key product attributes in spreadsheet format (ORTC equivalent) and supporting text discussing business and state of the art issues**

Emulators	Characteristics
Portable / Consumer	High volume Consumer Products for which cost is the primary driver including Hand held, battery -powered products driven by size and weight reduction
Office / Large Business / Communications Systems	Products which seek maximum performance from a few thousand dollar cost limit to literally no cost limit
Medical Products	Products which must operate within a highly reliable environment
Automotive	Products which must operate in an automotive environment
Defense and Aerospace	Products which must operate in extreme environments

Product Sector Needs Vs. Technology Evolution

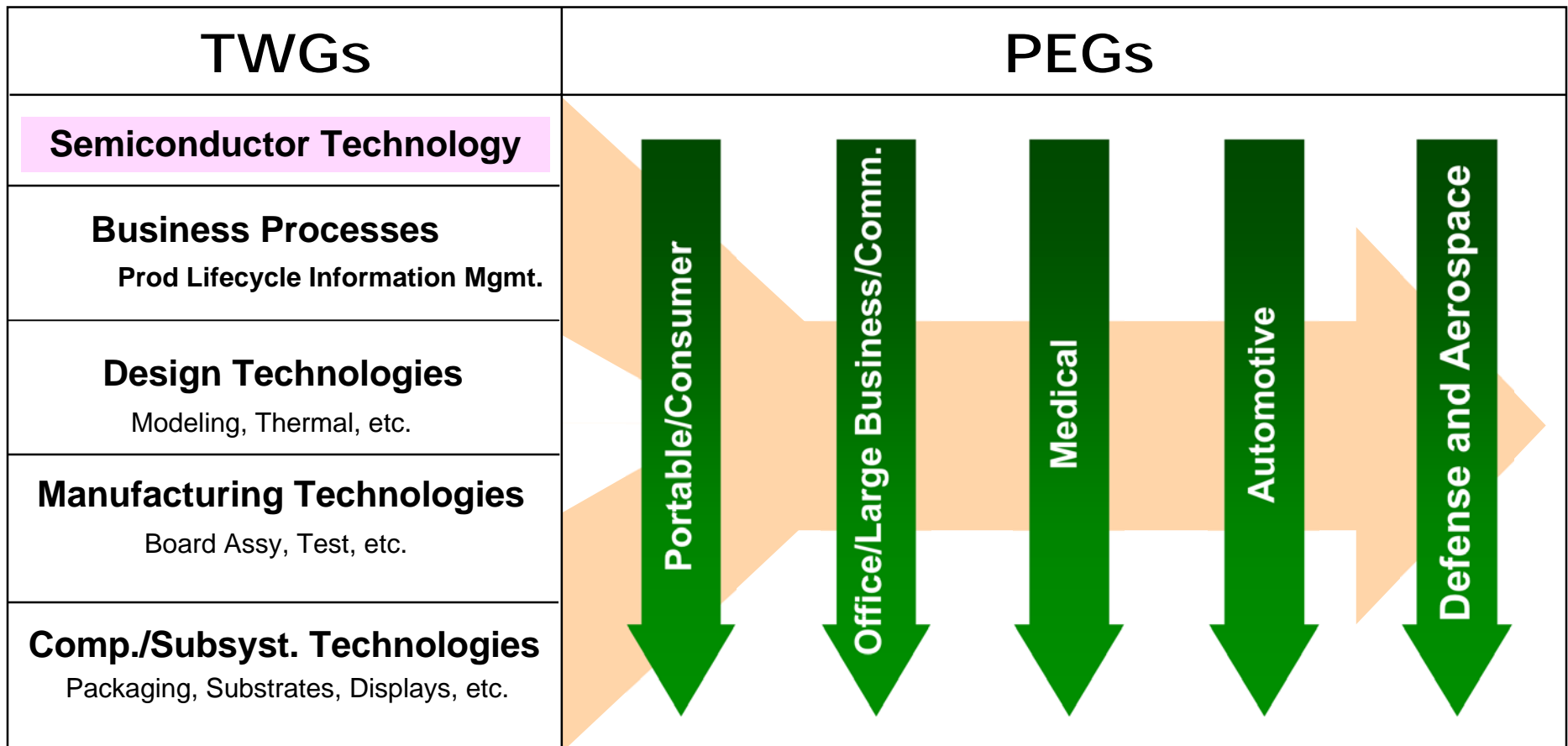

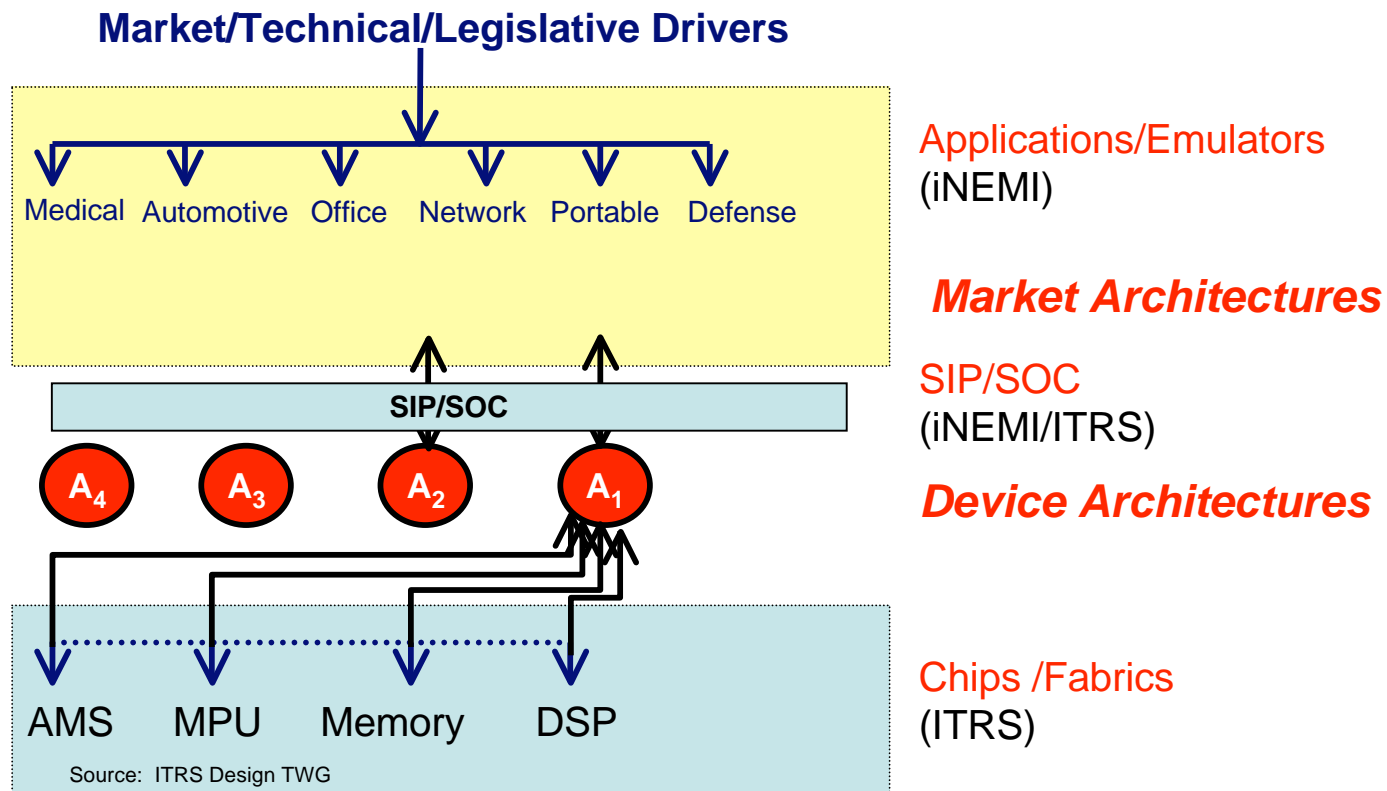

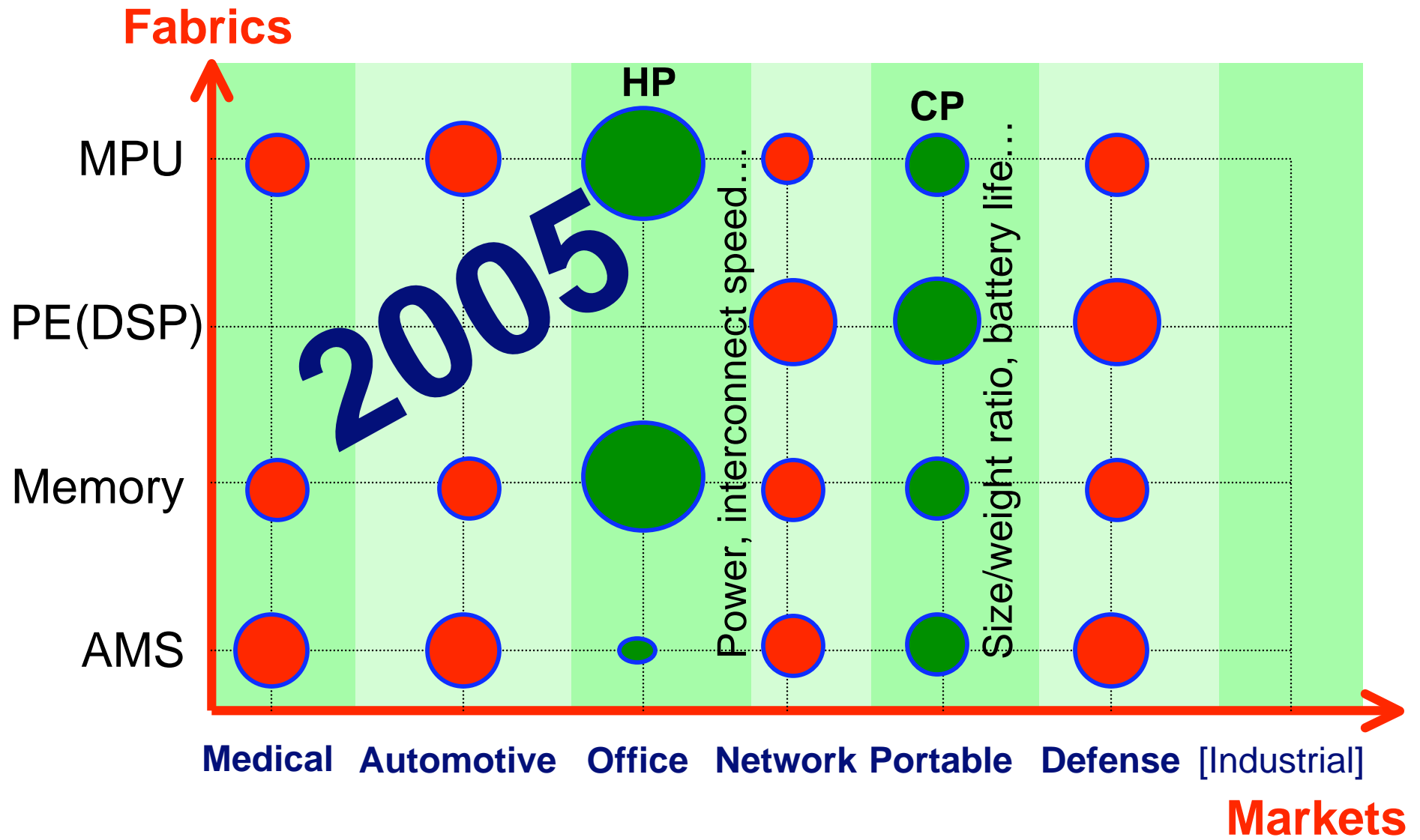

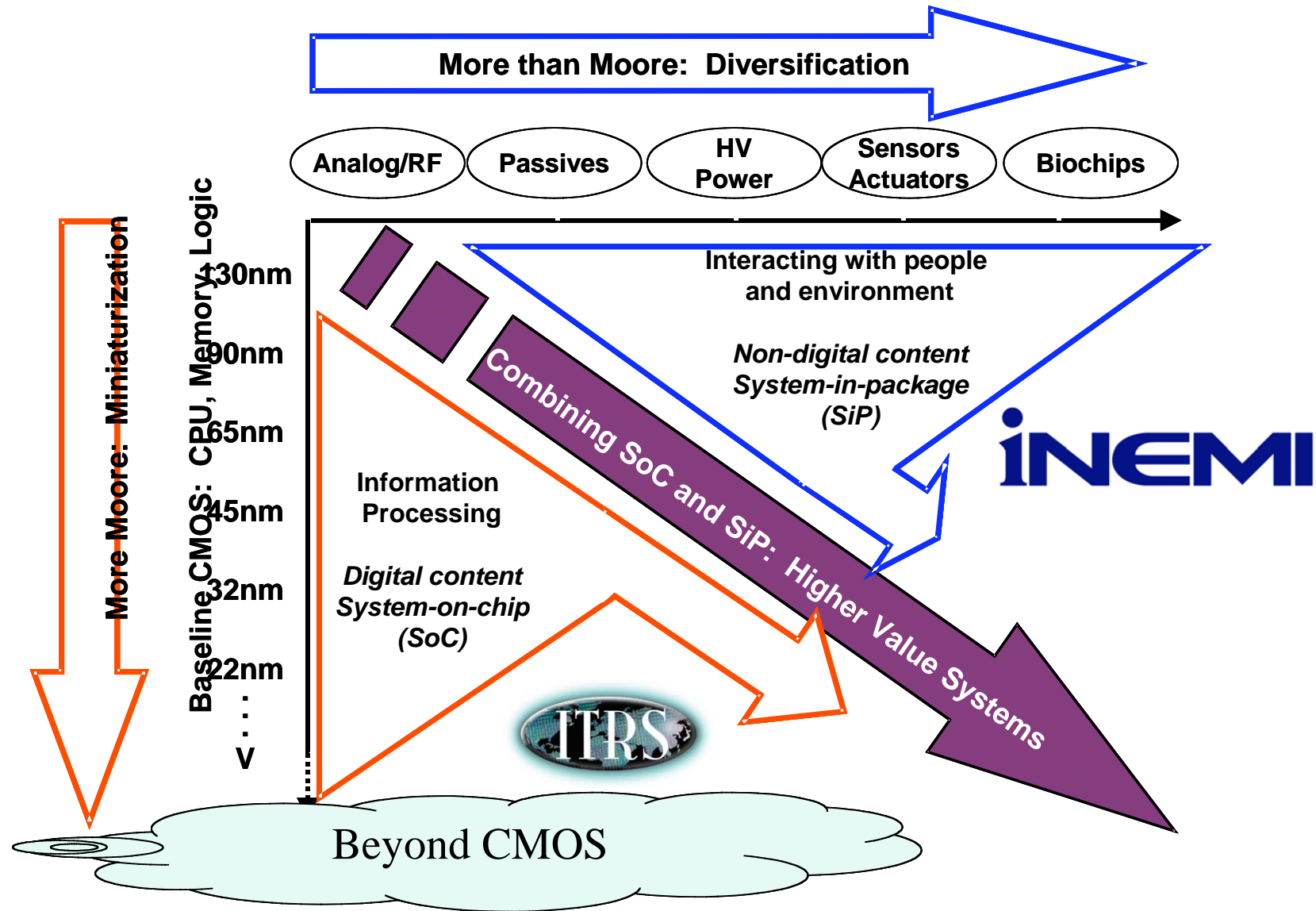



International Electronics Manufacturing Initiative

The iNEMI Roadmaps



- **> 470 Participants**
- **> 220 Companies/organizations**
- **11 Countries from 3 Continents**
- **19 Technology Working Groups (TWGs) (added Sensors)**
- **7 Product Emulator Groups (PEGs)**
- **Over 1200 Pages of Information**
- **Roadmaps the needs for 2005-2015**

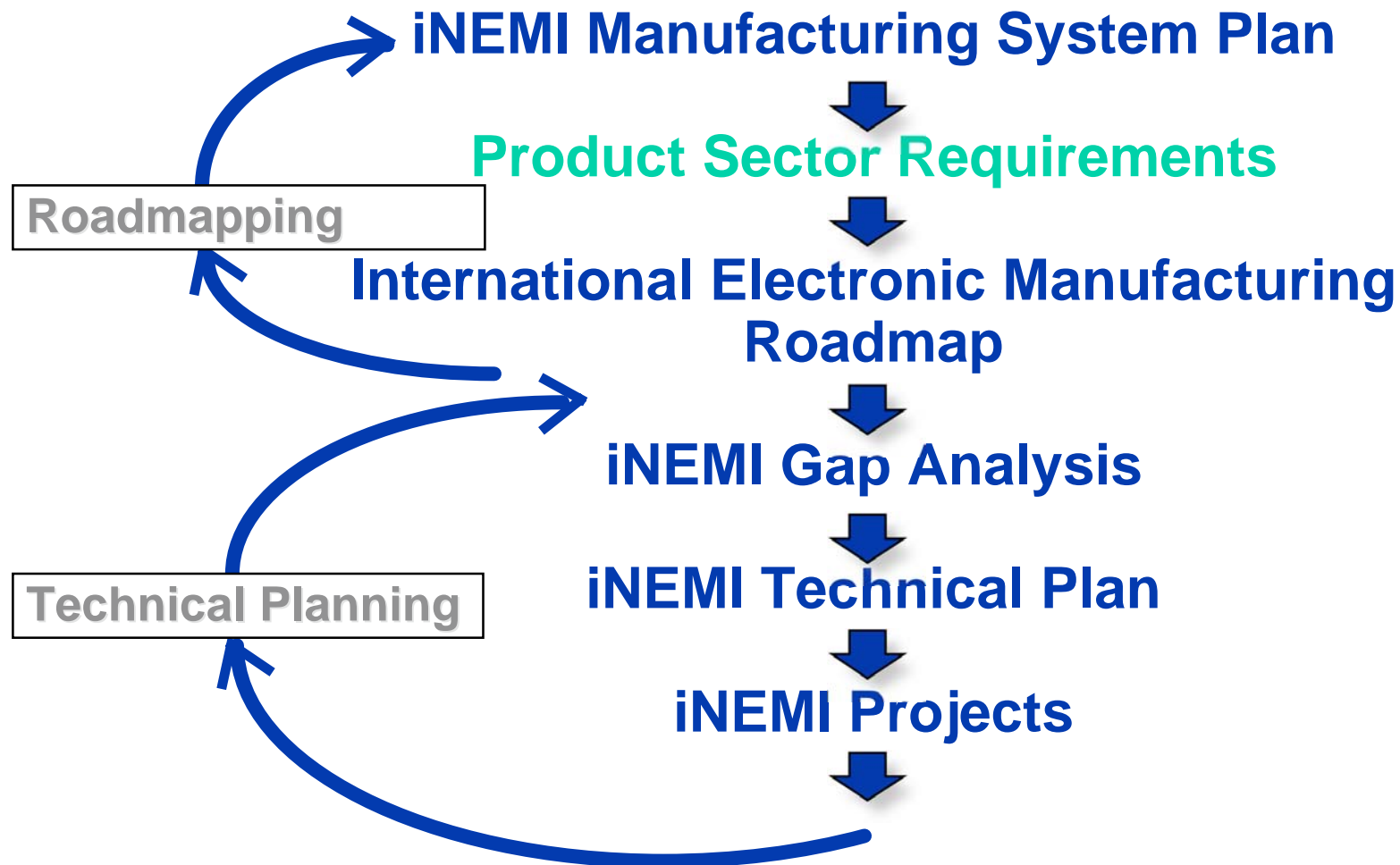

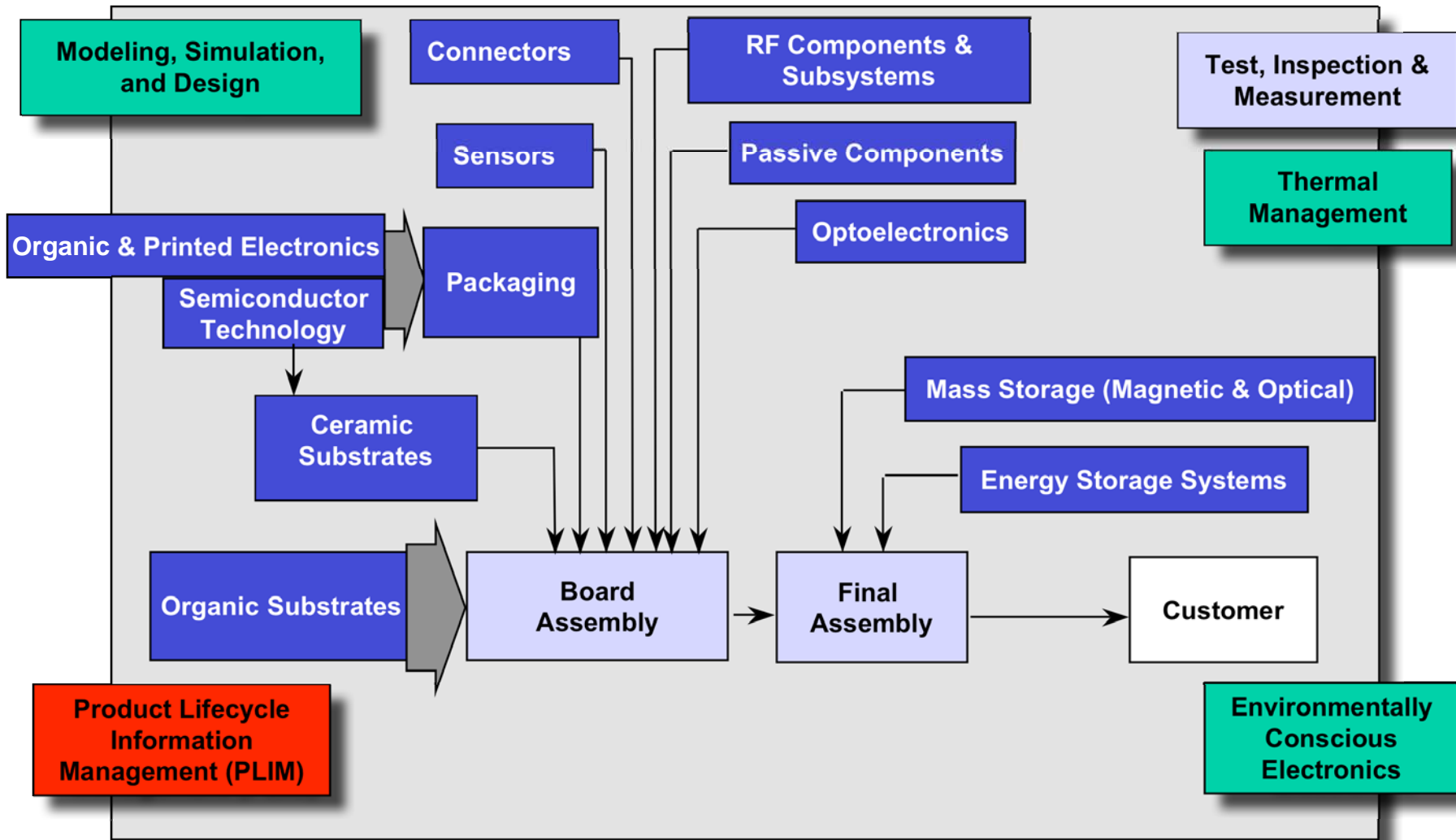

Red=Business Green=Engineering Blue=Manufacturing Blue=Component & Subsystem

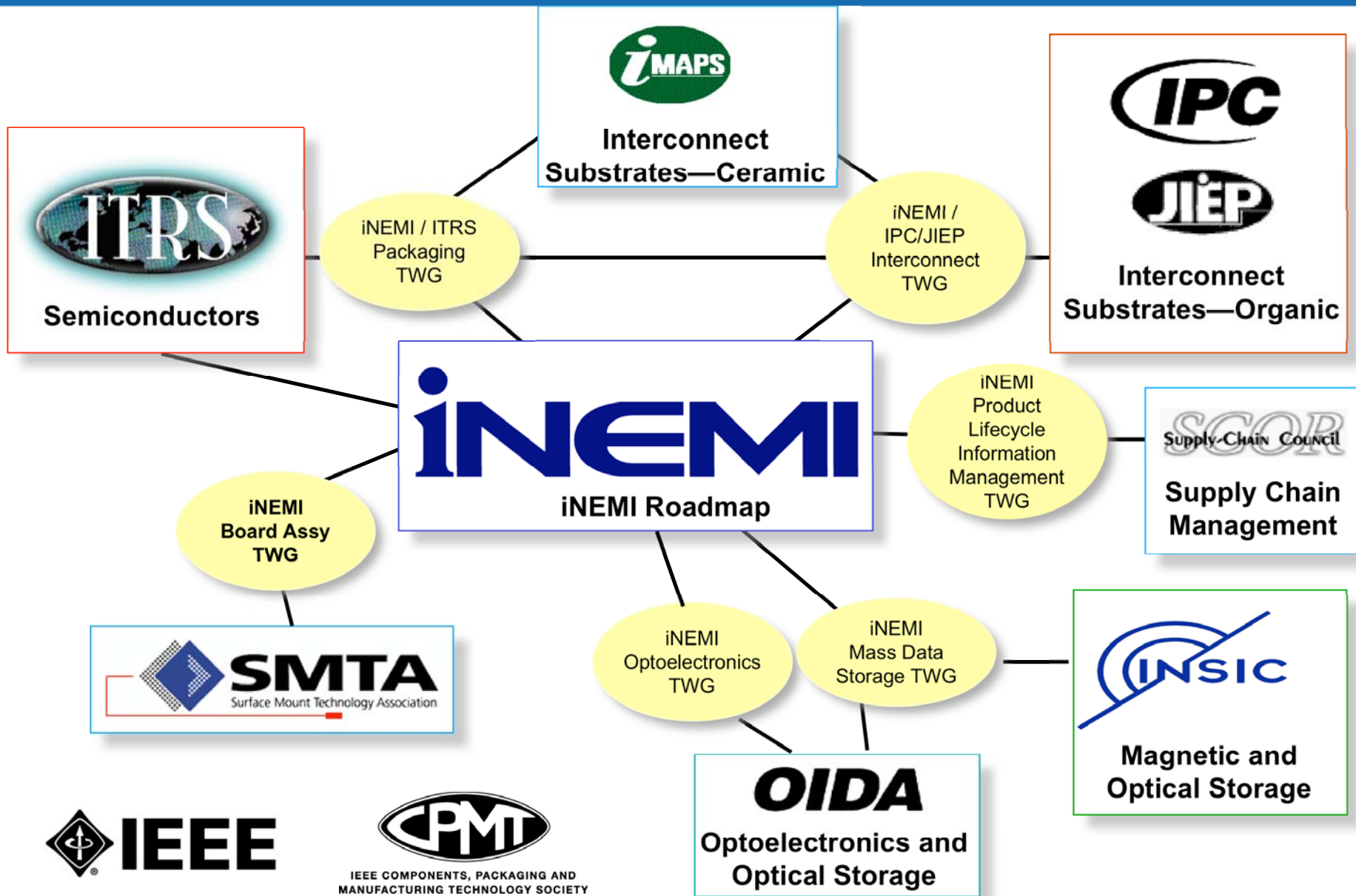

- Executive Summary (half page)
- Introduction

- **Situation (Infrastructure) Analysis**

Benchmarking

- Manufacturing Equipment
- Manufacturing Processes
- Materials
- Quality/Reliability
- Environmental Technology
- Test, Inspection, Measurement (TIM)

- **Roadmap of Quantified Key Attribute Needs**

- **Critical (Infrastructure) Issues**

Roadmapping

- **Technology Needs:**

- Prioritized Research, Development
- Implementation

- **Gaps and Showstoppers**

- **Recommendations on Potential Alternative Technologies**

- **Contributors**

Recommendations

CHAIN

- **Equivalent to ORTC**
- **Provided in tabular form for the 10 year roadmap period**
- **At least one metrics from each TWG**
- **Metrics include performance, size, cost, and cycle time**
- **Key changes from previous roadmap are identified, often indicate a paradigm shift.**

- **Change Name to Better Reflect Year of Release.**
- **Maintain strong linkages with other roadmaps.**
- **Maintain emphasis on disruptive events (business & technical).**
- **Maintain emphasis on identifying market needs and business situations.**
- **Increase quantification of needs.**
- **Prioritize Research and Deployment needs.**
- **Increase strategic vision of the roadmap: 2011-2017**
- **Improve and expand sensors chapter**

- **3Q 2005: Select Product Sector Champions and refine data charts**
- **3-4Q 2005: Product Sector Champions Develop Emulators**
- **Organizing Teleconference with TWG Chairs 1/11/2006**
- **February 2006 PEG Workshop/TWG Kick-off at APEX Meeting in Anaheim:**
 - **Product Sector Tables Complete – Chapters Written**
 - **Cross cut issues addressed**
- **2Q2006: International Public Workshop Reviews**
 - **April - Roadmap Workshop Europe in Munich, Germany**
 - **May - Roadmap Workshop in Herndon, VA**
 - **June - Roadmap Workshop in Shanghai, China**
- **July 2006 – TWG Drafts Due for TC Review**
- **September 2006 – Council Review of Key Issues and Summary**
- **December 2006– Release to iNEMI Members**
- **February 2007 – Industry Release at APEX**



International Electronics Manufacturing Initiative

*Conclusions from the
2004 Roadmap/2005
Research Priorities*



- Gap analysis completed
- 10 year priorities created
- Available on the web
- Contents:
 - Technology Research Needs by Product Sector
 - Priorities Summarized by Research Area
 - *Manufacturing Processes*
 - *System Integration*
 - *Materials & Reliability*
 - *Energy and the Environment*
 - *Design*
 - Significant Gaps and Issues from Roadmap
 - Options for Innovation



- **Active Device Technology**
- **Thermal Management**
- **Communications Bandwidth**
- **Next Generation Packaging Technology**
- **Design and Simulation Tools**
- **Sustainability Metrics**

- Implementation of advanced, non-classical CMOS devices with enhanced drive current
- Identification, selection, and implementation of advanced devices (beyond-CMOS)
- Device technology drives the following three strategic system gaps:
 - Thermal Management
 - Communications Bandwidth
 - Next Generation Packaging Technology

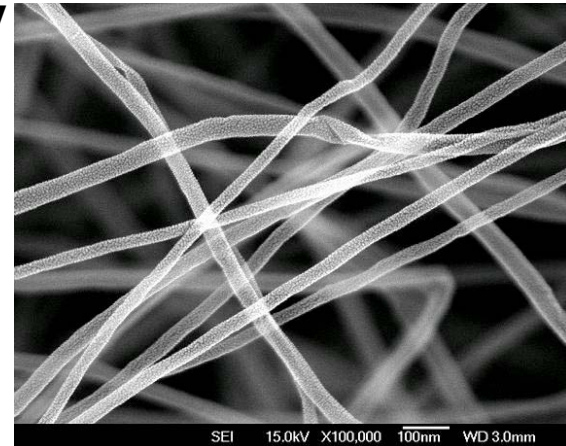

Multi-wall carbon nanotubes (NanoDynamics Inc.)

- **Increased need for improved cooling**
- **Improved materials and design concepts**
- **Focus is on local hot spots**
- **Must design from device to system level.**

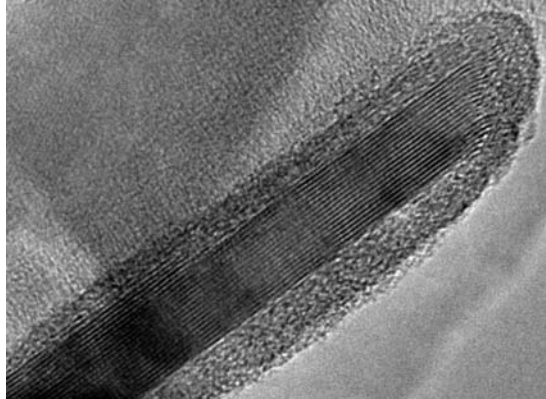

BN coated with Al₂O₃ (ALD Nanosolutions Inc)

- Copper?
- RF?
- Optical?

- Where?
- When?
- How Fast?
- **At what cost?**



Will the 2007 roadmap provide guidance?

Innovative Miniaturized Packaging

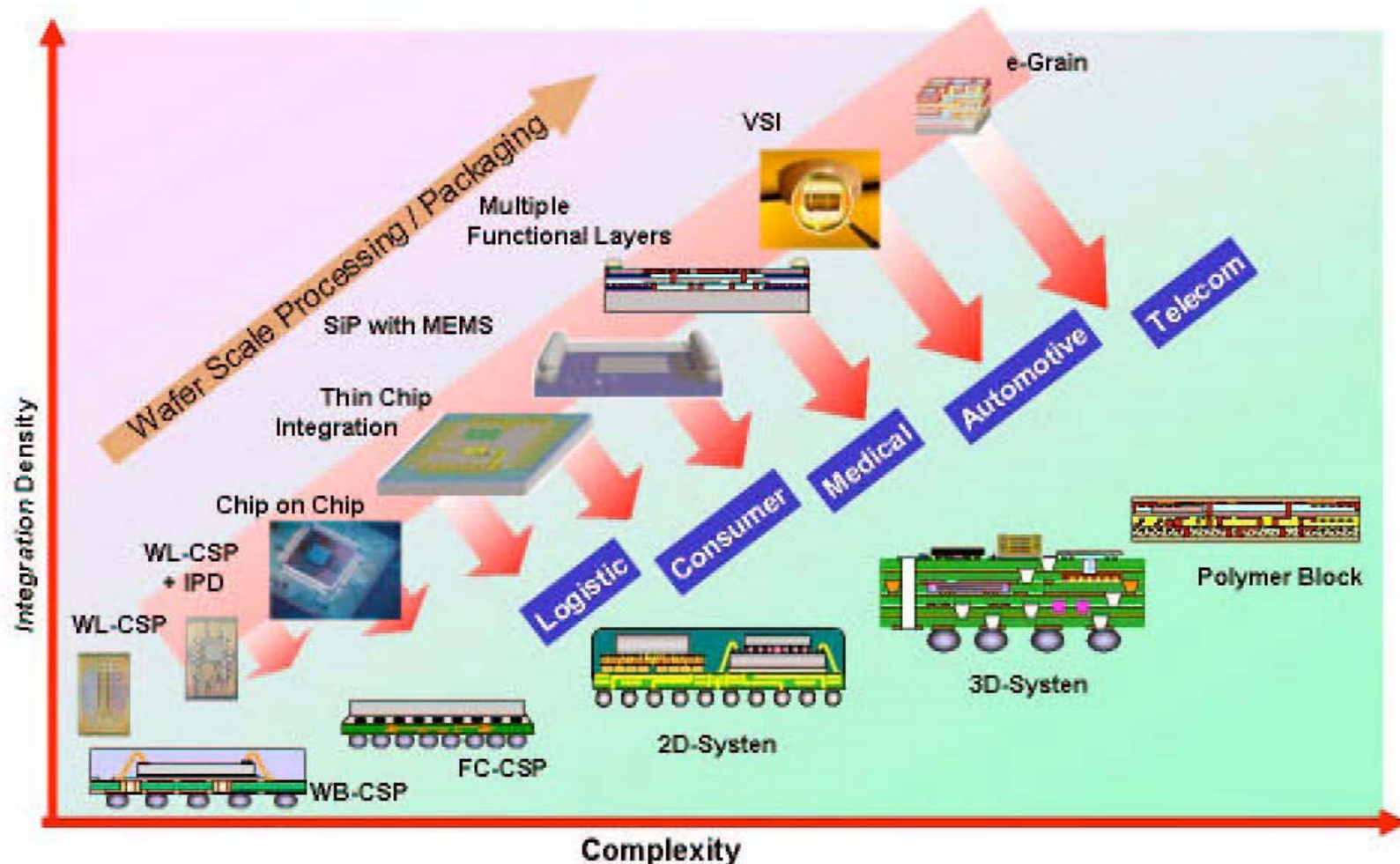

Source: Professor Dr. Reichl, Fraunhofer IZM, Berlin Germany

Design & simulation tools are main roadblocks to more rapid introduction of new technologies:

- **Multi-physics design (co-design)**
 - **Electrical**
 - **Mechanical & reliability modeling**
 - **Thermal & thermo-fluid simulation**
- **Multilevel Simulation**
- **Harsh Environment Simulation**
- **Nanoscale material behavior**

- **Development & implementation of scientific methodologies:**
 - **Assess true environmental impacts of materials**
 - **Potential trade-offs for alternatives**
- **Focus on system energy reduction at the beginning of the design process**
- **Develop a common, straightforward definition of sustainability**

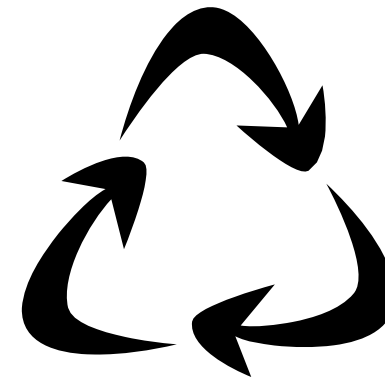



INEMI

International Electronics Manufacturing Initiative

Conclusion



iNEMI TWG	Chair	ITRS TWG	Chair	Recommended Action
Silicon Technology	Alan Allan	IRC	Paolo Gargini	Currently Coordinated
PLIM	Eric Simmon	Factory Integration	Mani Janakiram	
Modeling, Simulation, and Design Tools	Sanjeev Sathe	Modeling & Simulation	Jürgen Lorenz	Start Dialogue
ECE	Mark Newton	ES&H	Jim Jewett	Increase Dialogue
Test, Inspection, and Measurement	Michael Reagin	Test & Test Equipment	Mike Rodgers	
Packaging	Joe Adam	Assembly & Packaging	Bill Bottoms	Same TWG
RF Components	Eric Strid	RF &A/MS	Margaret Huang	Start Dialogue
Product Emulator Groups		Design and System Drivers	Juan-Antonio Carballo	Working together

- **Broad global industry participation**
- **Global acceptance as the source that provides a system view of electronics manufacturing**
- **Coordinated with other major organizations: ITRS, IPC, JIEP, OIDA, NSIC, Supply Chain Council, SMTA, IMAPS, CPMT**
- **Has accurately predicted needs for a number of disruptive technologies: Area Interconnect, Microvia PWB, Pb-Free solders**
- **Evolving to address changing markets and priorities: Convergence of Products and Markets, Supply Chain Management, Environmentally Conscious Electronics, Distributed Manufacturing Model, System in Package, Medical Systems**

www.inemi.org

Email contacts:

Bob Pfahl

bob.pfahl@inemi.org

Chuck Richardson

chuck.richardson@inemi.org