

Future Directions in Miniaturization

iNEMI, January 16, 2008, Shanghai

- Continuous technology development and integration has enabled mobile products be evolved from voice only to multimedia devices
- The ability to miniaturize functionality in devices and components has become an important driver in the emergence of new types of portable electronic products.
- Forthcoming products may require revolutionary technology for integration

Seppo Pienimaa, Laboratory Director



Nokia Research Center

16.01.08

iNEMI_Shanghai 2008_01_16, Seppo Pienimaa

NOKIA

Access on Media in future – interactive & augmented

Media market by segment, 2001-2009 Percent

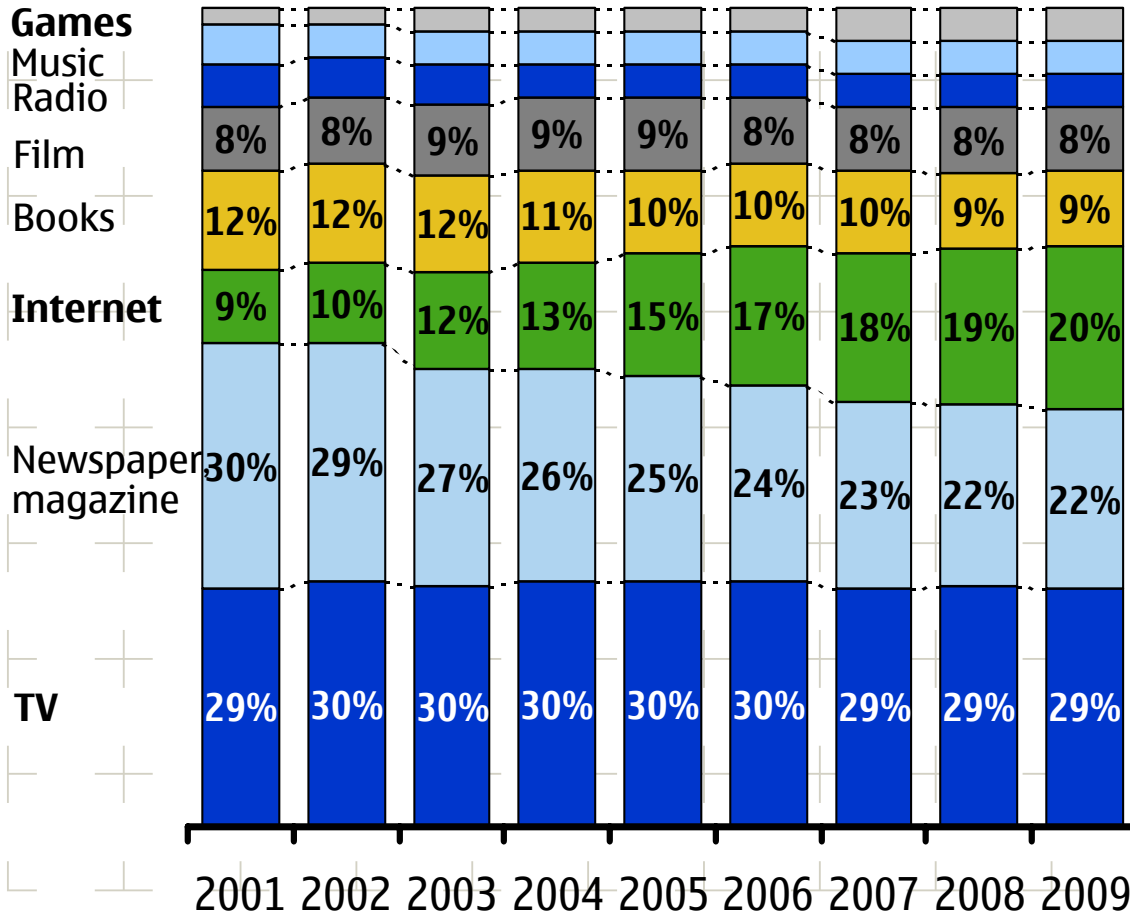

TV is the most significant media sector with 30% of the market
 Internet is taking share from other media sectors

Sources: PwC, Nokia CS



Nokia Research Center

NOKIA

Be Mobile

Open HW Architecture



Desktop



Laptop



Network on Terminal



Home Electronics



Vehicle Electronics

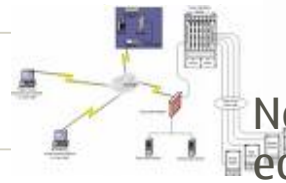

Network equipment



PDA



Human on move
Form factors

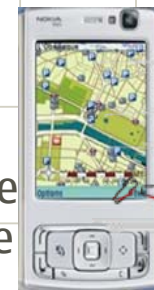

Mobile Phone

Computing power in device and in network

Interoperable functional blocks with controllable HW elements

Truly interactive and productive on move

Static

Mobile

Complexity Management



Nokia Research Center

NOKIA

Access to Applications as the Driver

Differentiation



Wearable



One hand Mobile



Touch Input Mobile



Two hand Mobile

Integration



Nokia Research Center

NOKIA

Camera as an Input

- 140 million connected cameras sold in 2006

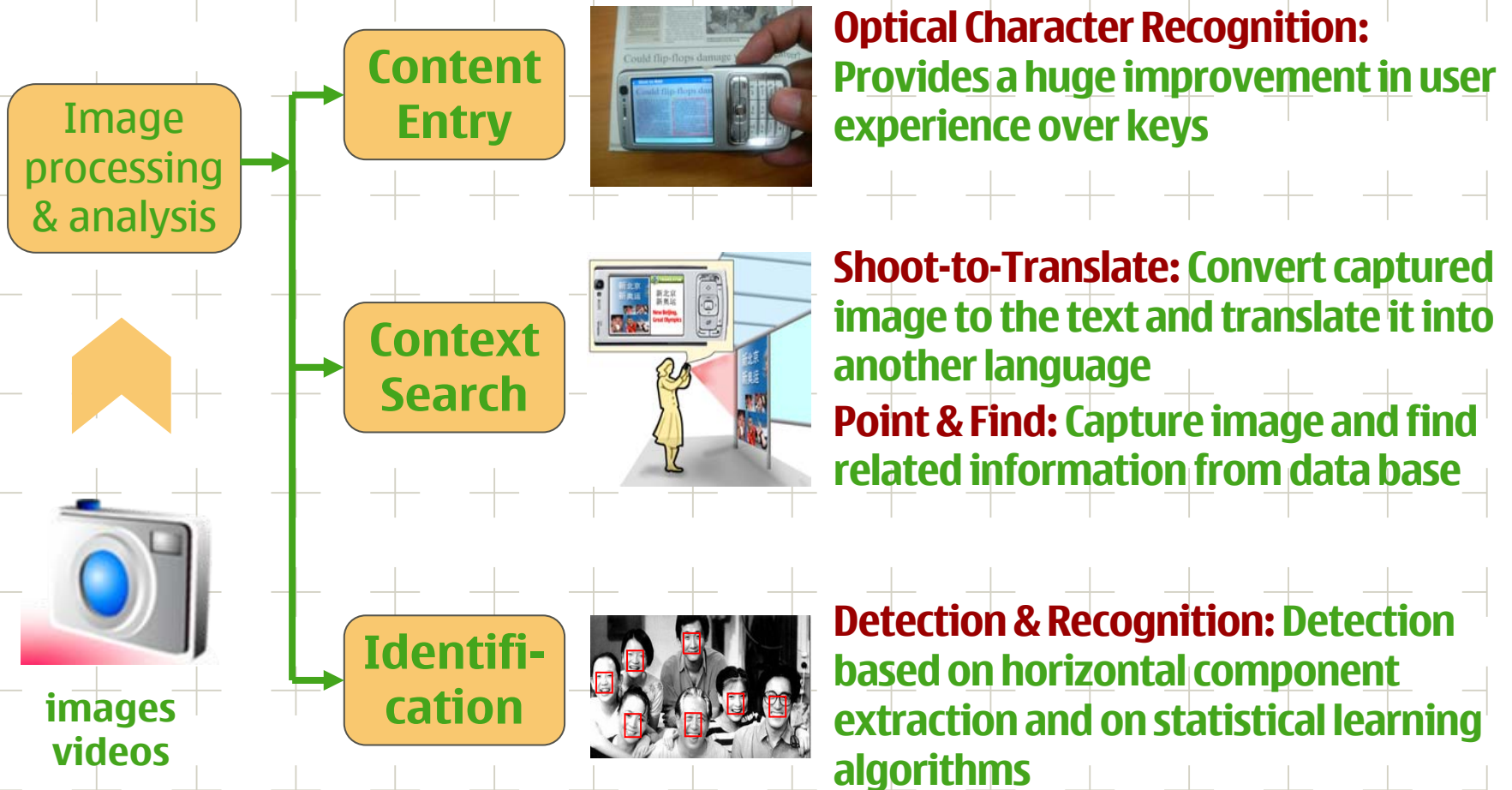

Content Creation and Manipulation

Easy way to create and edit media content for Mobile Internet services, e.g., Blog, Wiki, news desk, ...

Media creation and manipulation

- To develop core algorithms for processing handwritten scripts for showing, editing, storing and sharing



Story visualization

- To design and implement touch user interfaces for visualizing stories for education and entertainment purposes



Image manipulation

- Touch UI for image content manipulation



Interactive streaming download on move

- To create traffic-effective UI solution for interactively downloading media streaming



Elements to Miniaturize while Maximize Experience

Power management

User experience

Materials

Cellular Radio

Mechanics

Software and Applications

Cameras and optics

Voice & Video codecs

Electronics



Algorithms

Proximity



Mechanics & Materials

Miniaturized communication device with human-like user interface

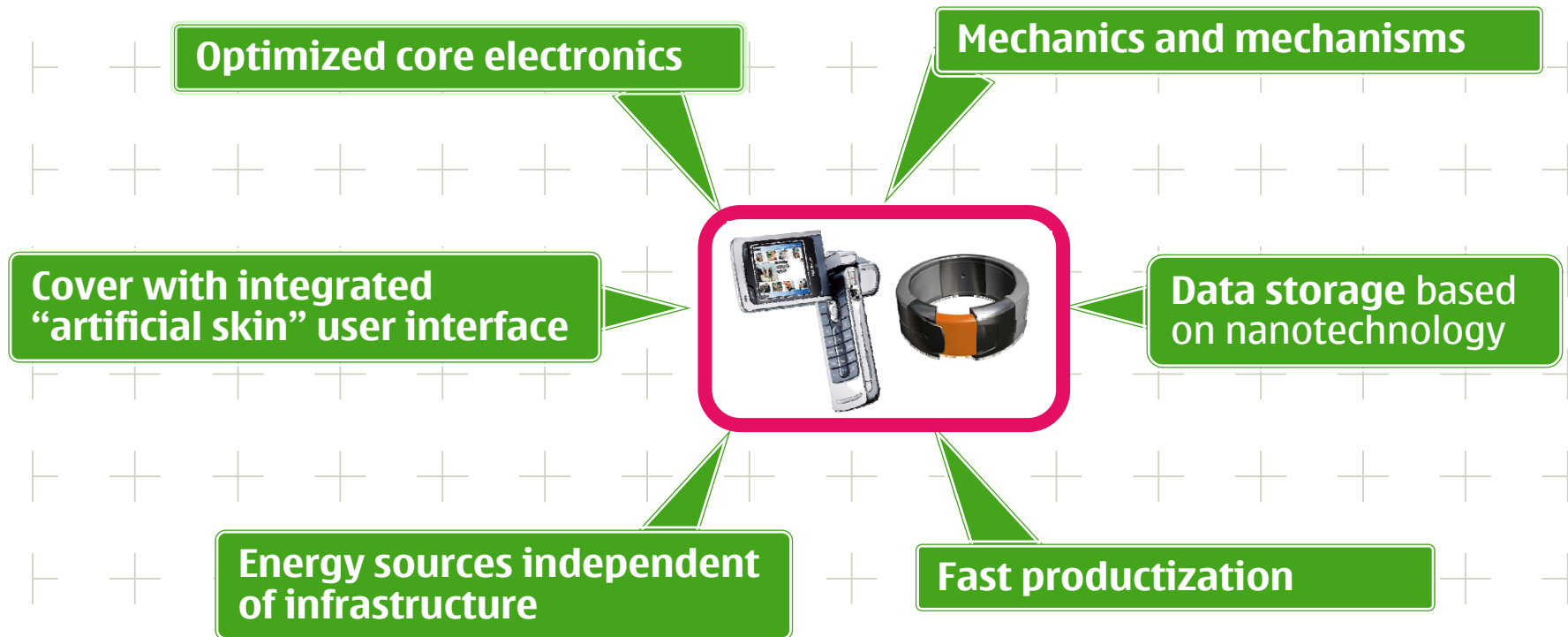

Mobile industry seeks benefits of nanotechnology

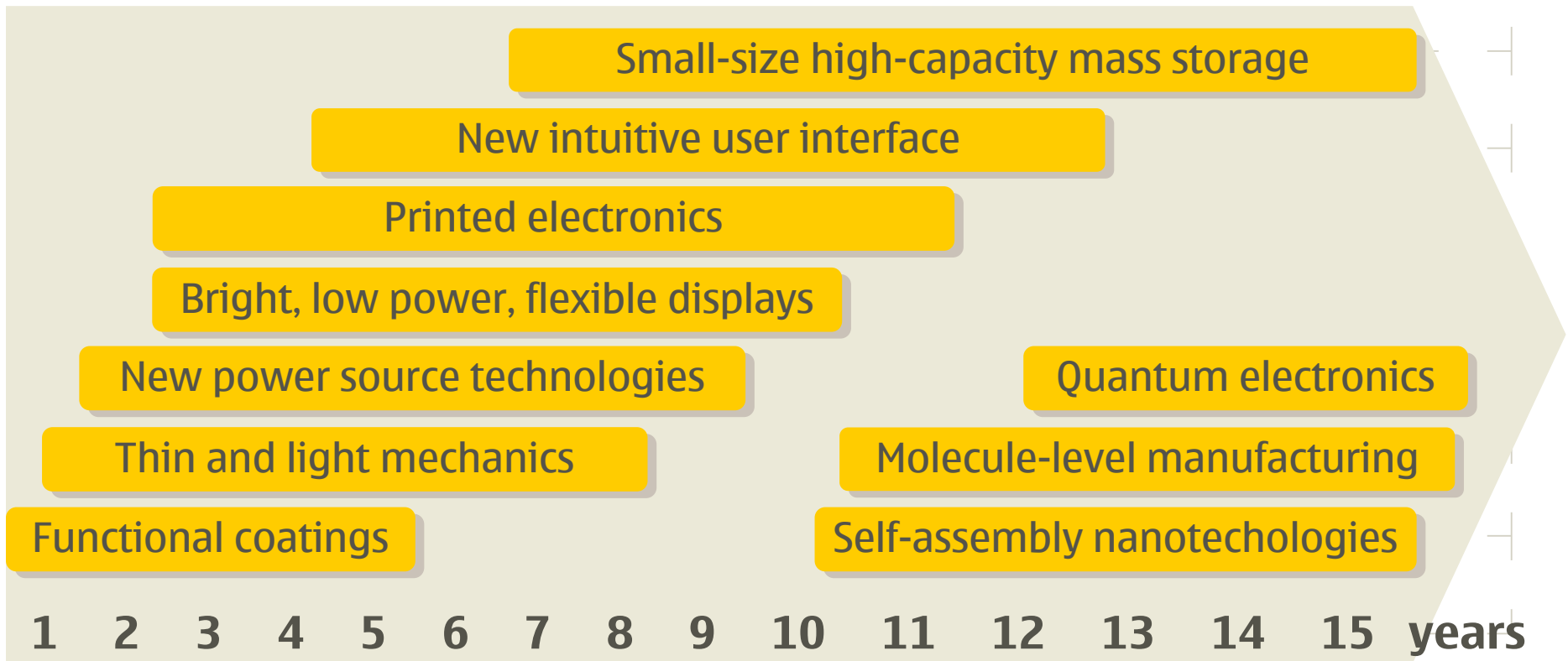

Smart Integration and Nanosizing

The main targets for the technology development are:

- going toward low cost materials and fast processes.
- improvement of performance
- miniaturization of size

These factors open up new possibilities both for:

- further miniaturization of current products,
- and for design of totally new product concepts where the communication devices are either integrated with other electronic products, or they are small devices dedicated only for some specific functions and for short-distance communication

And interest to Miniaturization/Nanosizing

- Optical waveguides, detectors and modulators
- Nano RF components
- Molecular electronics

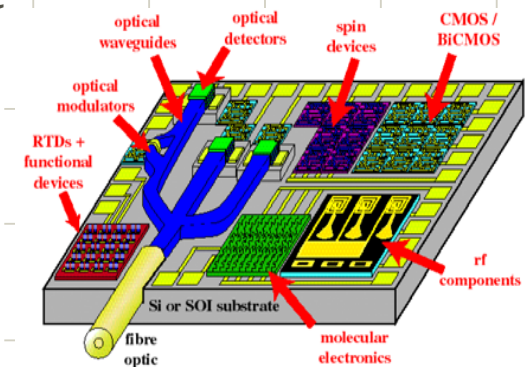
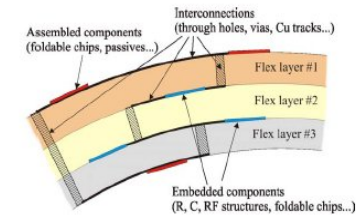

System-in-Package

- System in Package is providing integration flexibility of multi technologies, lower R&D and NRE cost and faster time to market.
- Fast product creation through modular architecture (minimized I/O count & common bus) and compatible SiP core electronics modules.
- Mixed signal modules for wireless and complementary wireless radios. Multi Chip Modules and vertical packages for digital and memory electronics.
- Core modules developed and manufactured with specialized providers benefiting SiP and SOC technologies (complementary wireless, wireless and camera modules).
- New ways to connects chips
 - Digital printing
 - Nanograss electrical connections
 - Capacitive coupling

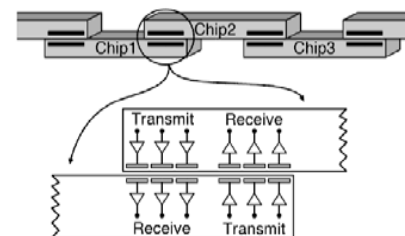
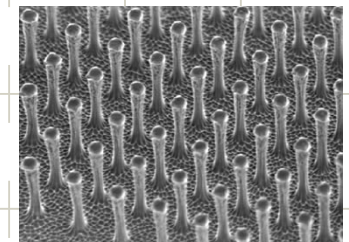
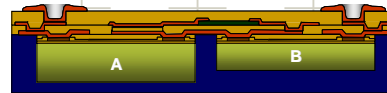

Electronics Integration by digital printing

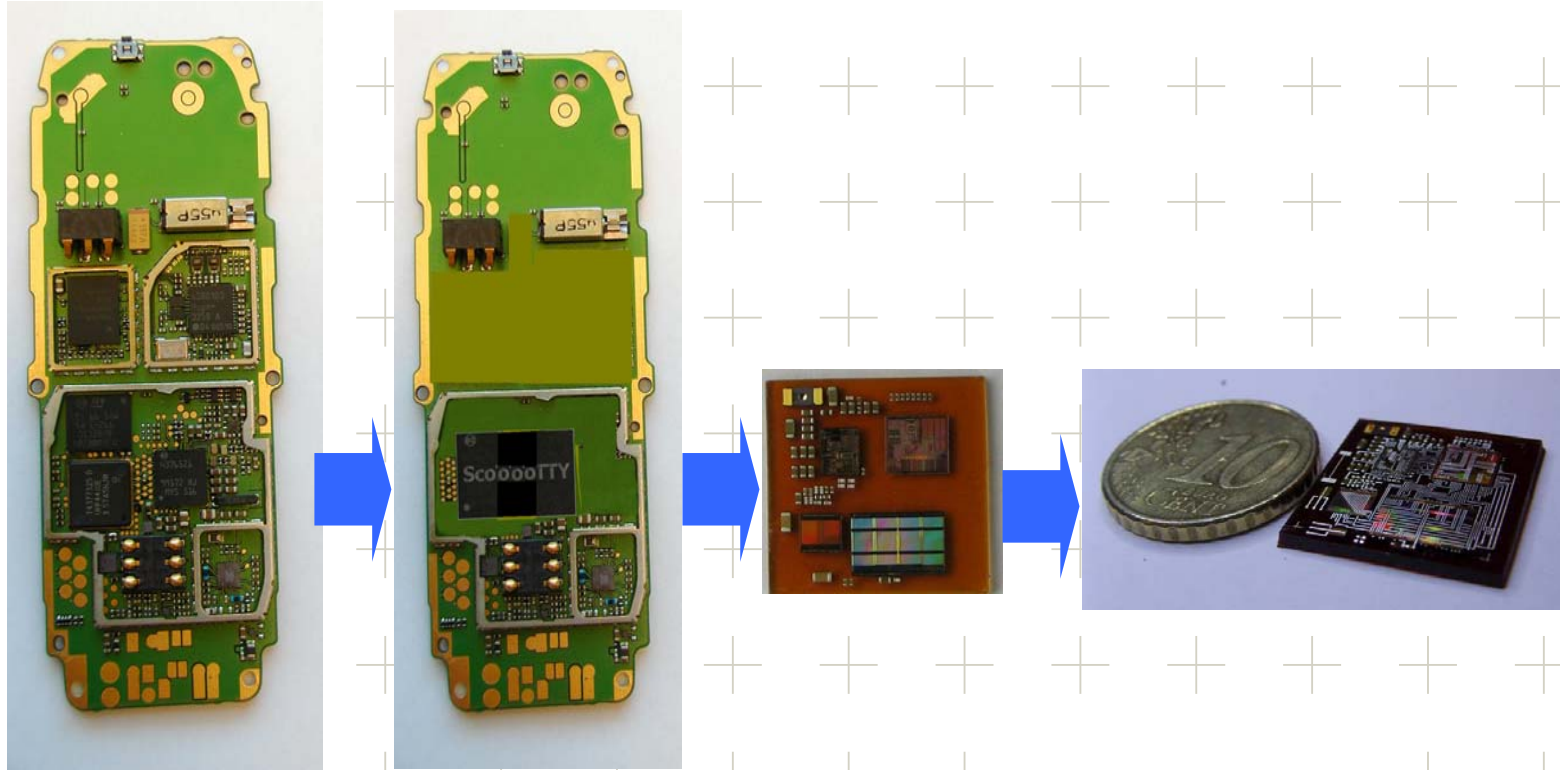

Embedded/Integrated Components

- Embedded passives: Integrated at silicon area, passives on top of silicon, stacked components/interposers, and integration into substrates.
- Integration of shielding into IC Package so you don't need it separately. This can cause changes in how you interconnect to IC Package

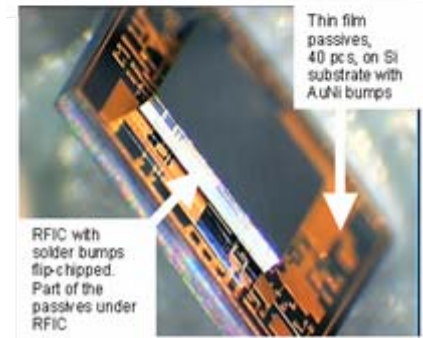
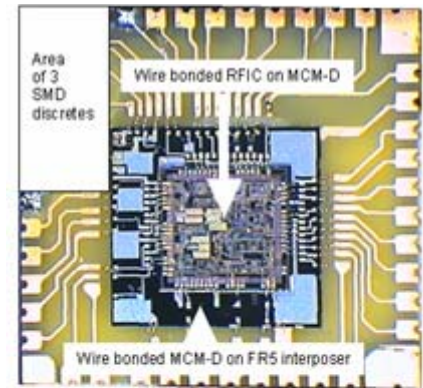
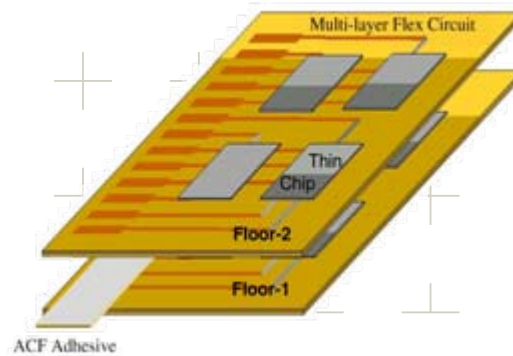

Miniaturization – Big experience in small size

- User Interface is increasingly important to provide exiting experiences
 - Video, internet, games etc. require high resolution display: at least ½ million pixels is needed
 - Problem: The display should be larger than the device
 - Solution: Virtual Display



SVGA
800x600
200 ppi



101.6 mm



Virtual display

- A virtual image is created by optics
- The image is perceived to be large at a distance from the observer, *e.g.* 40" at 2m
- Very personal display
- Large display in small size

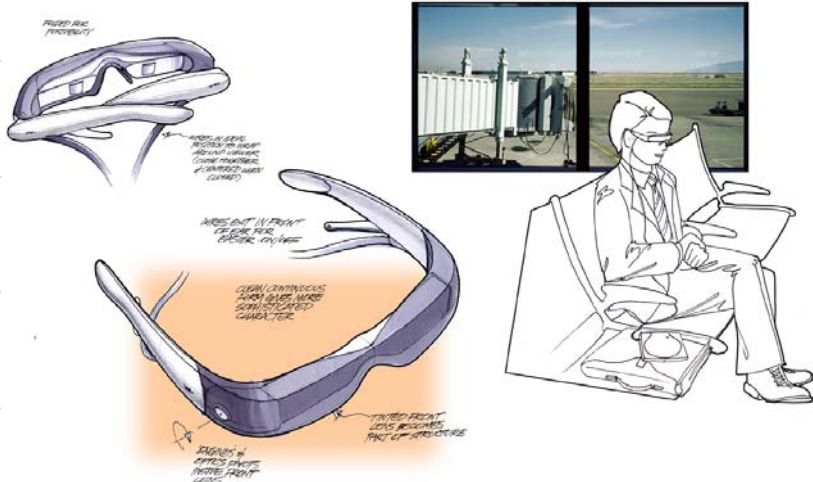
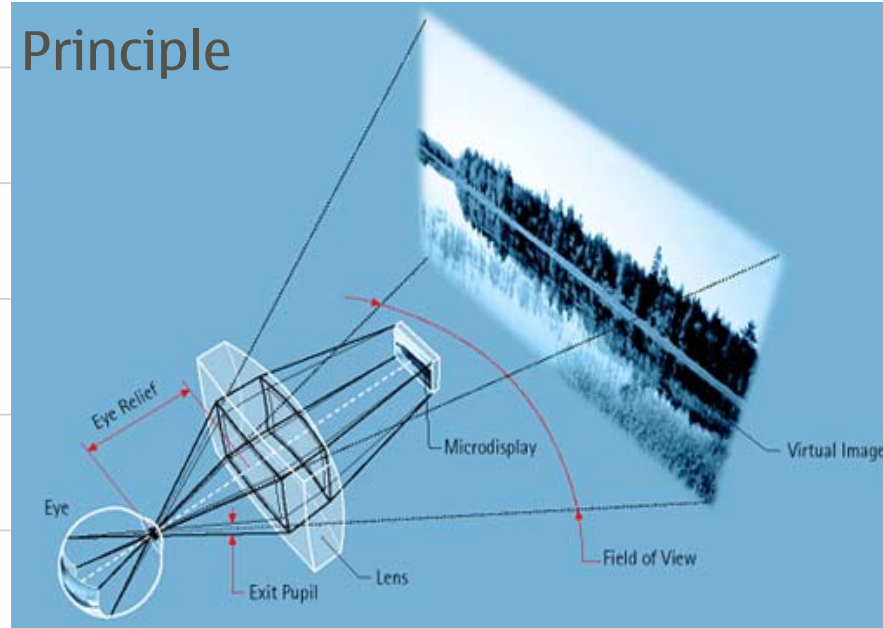

Summary

Key Drivers:

1. Experience

- Computer in hand & Network in hand (better applications and shorter latency) – thermal & power source challenge

2. Active on move

- Big experience in small size
- Greater use of 3D space in device

3. Cost

- Divergence between low cost /thin device and high end /rich device. Dramatic impact on global penetration. Ultra-low cost devices - High volumes.

Product lifecycles are short (15 months and decreasing), but it still takes ~ 10 years to bring major new HW technologies to market. Start now for needs of 2018. Whereas 10 year on SW and Service is eternity.

