

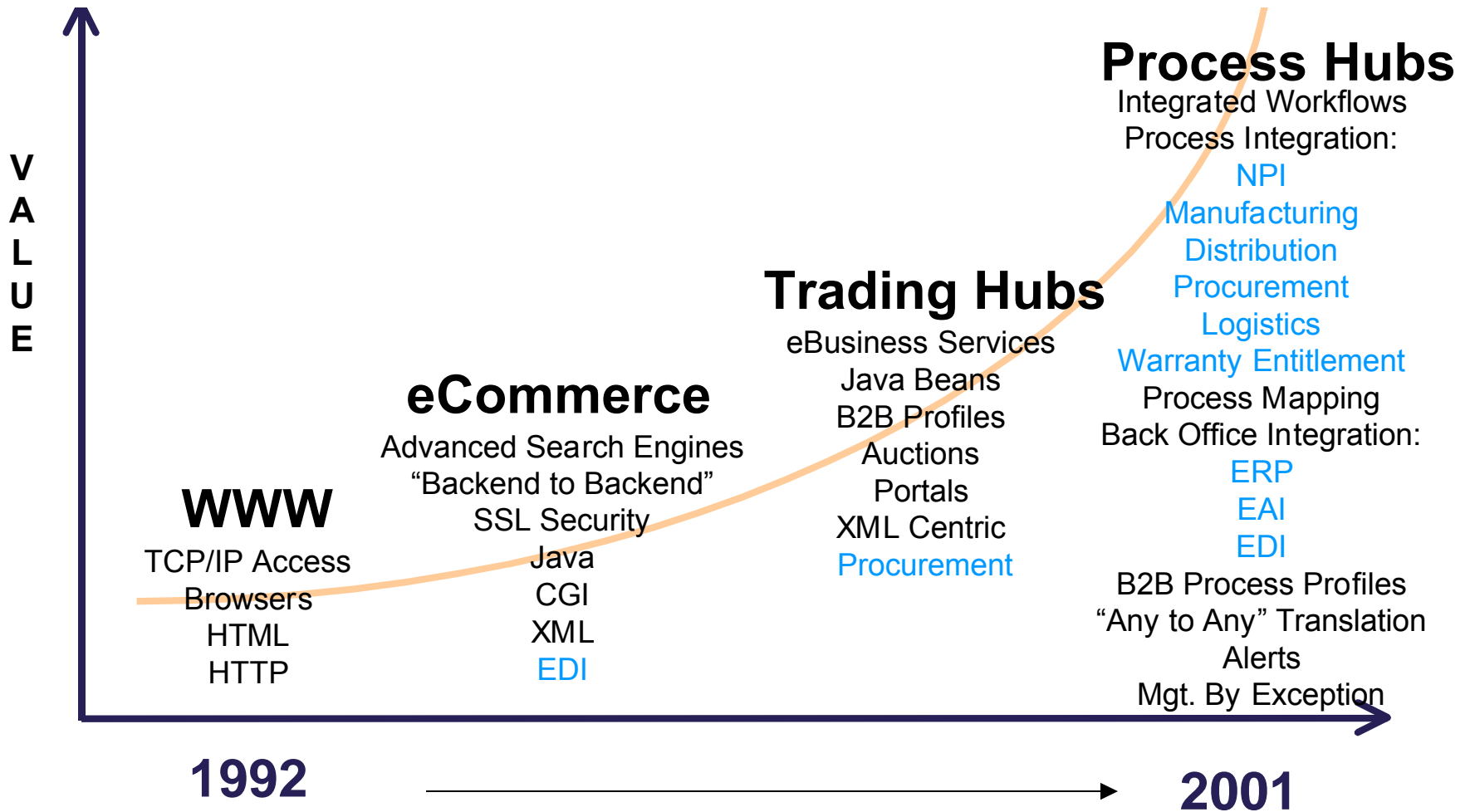

# B2B Roadmap

SCI - eEMS  
Process  
Collaboration





## e-EMS™ Integration Strategy

**SCI seeks to deliver secure, robust, business-to-business process integration solutions in the fastest possible time.**

**Exchanging Information in an “any to any” environment.**

**IT “Intelligent Workflow” Support for Business Rules and Engineering Collaboration.**

**Enable customers to achieve seamless, 100% secure collaboration with SCI and gain the agility to respond to changing market and program needs.**



# True B2B

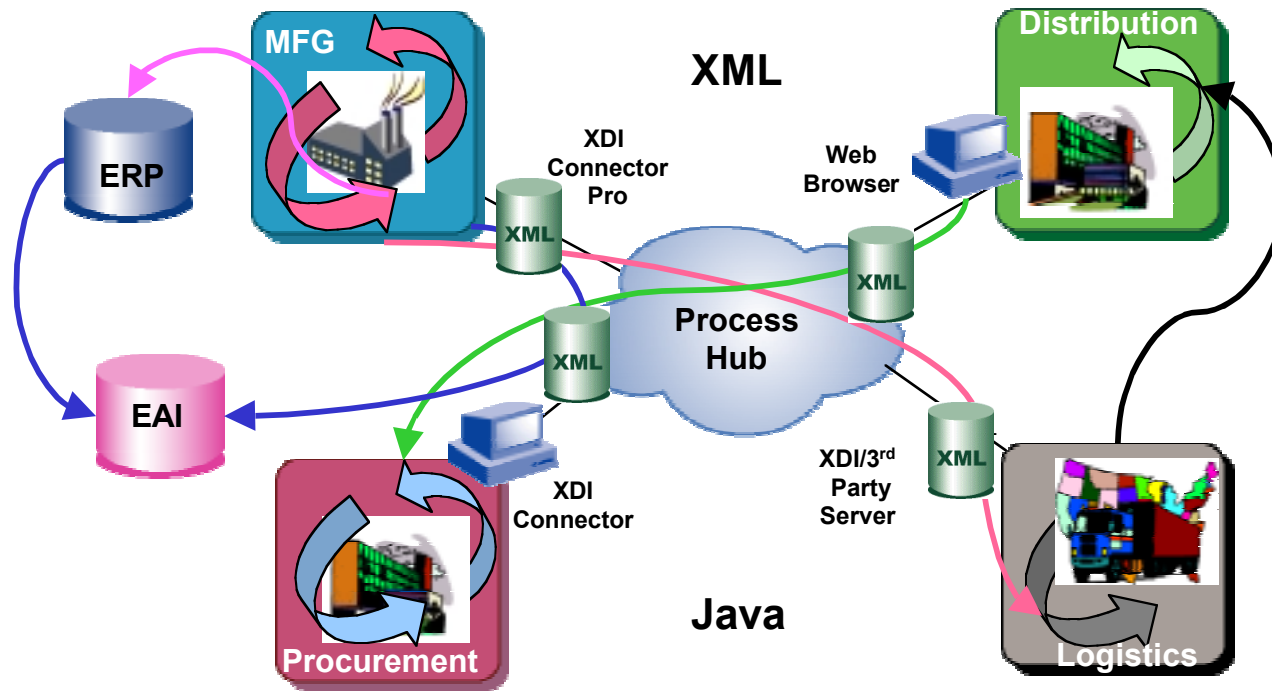



# SCI Corporate Overview

## Service Offerings

### Engineering

Electrical/Mechanical  
CAD/CAM  
ASIC Development  
Software  
Test SYSTEMS  
Stress Screening  
Validation Testing  
Failure Analysis  
Agency Certification

### Manufacturing

PTH & SMT PCBAs  
Electro-Mechanical  
Sub-Assembly Build  
Box (SYSTEMS) Build  
DFX Feedback  
Advanced Technologies

### Order Fulfillment

Build to Order  
Lot Size of One  
Configuration Management  
Software Loading  
Pack-out & Distribution  
Full Logistics  
Depot Repair Services



# A Full Service Engineering and Manufacturing Company

## Collaborating via XML gateway

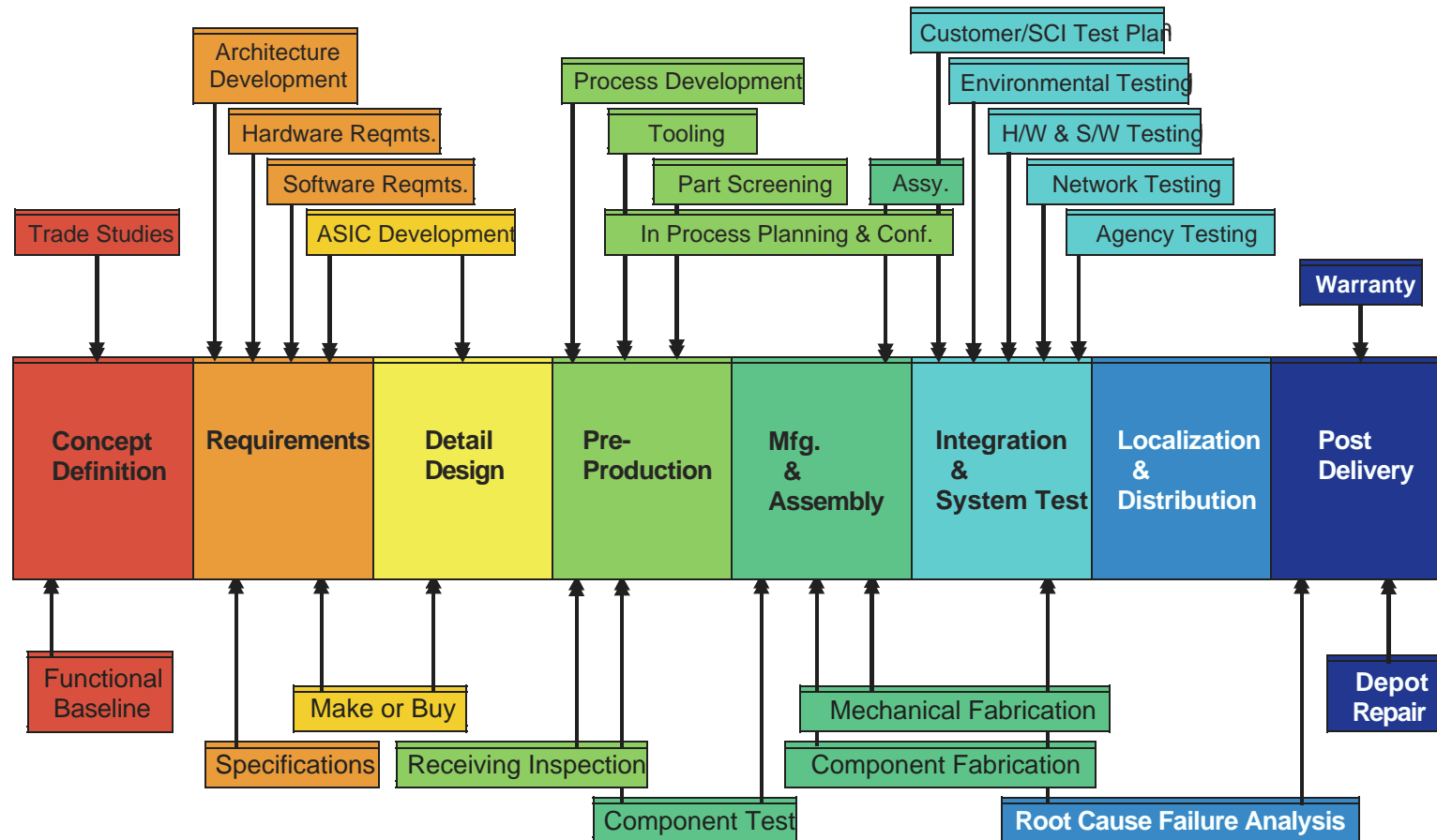



# Product Development

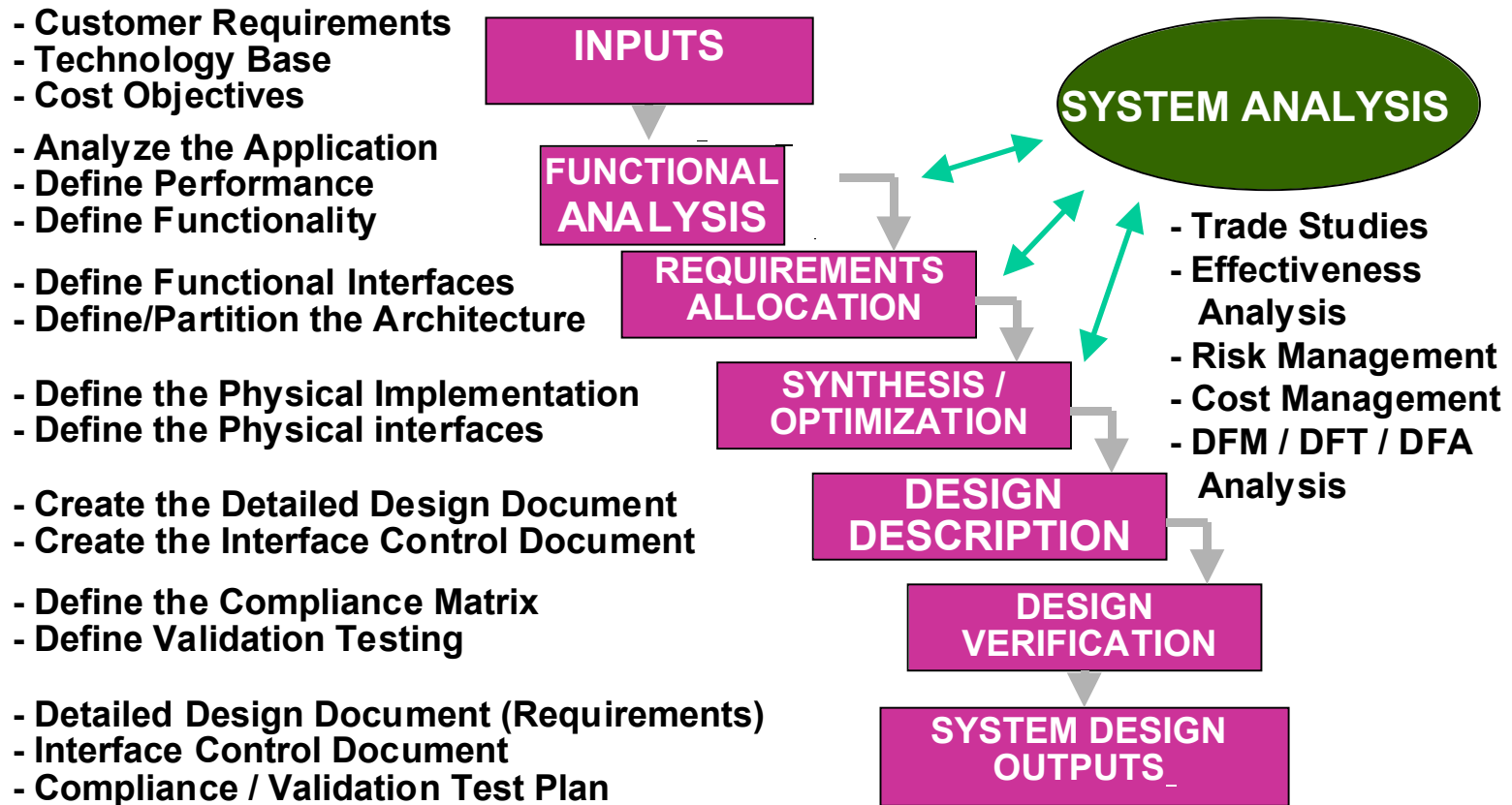



# Product Development Infrastructure

## *Product Design Flow*

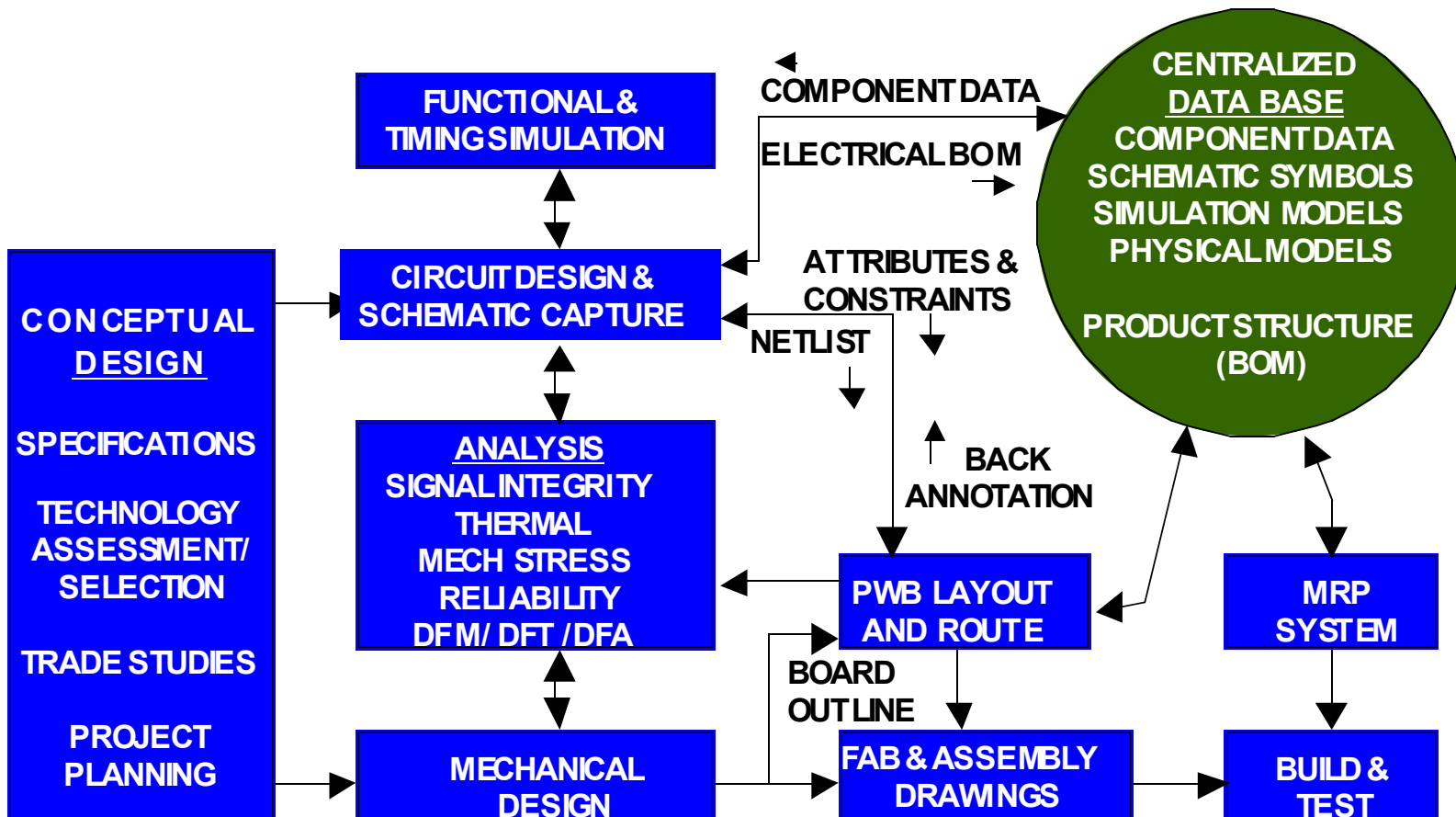



# The Challenge: NPI Integration Needing Standards

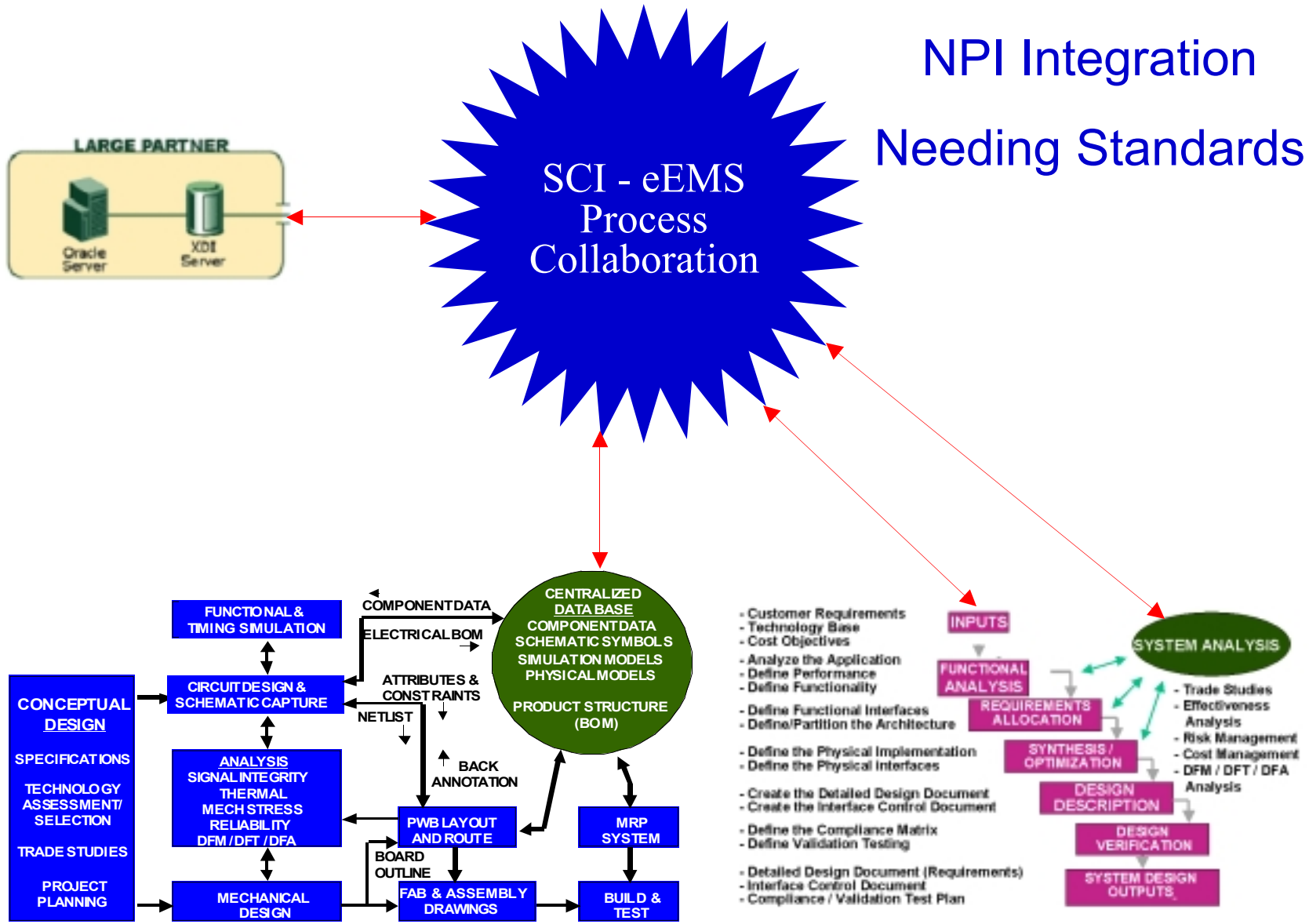



# VFIIP NPI Payload

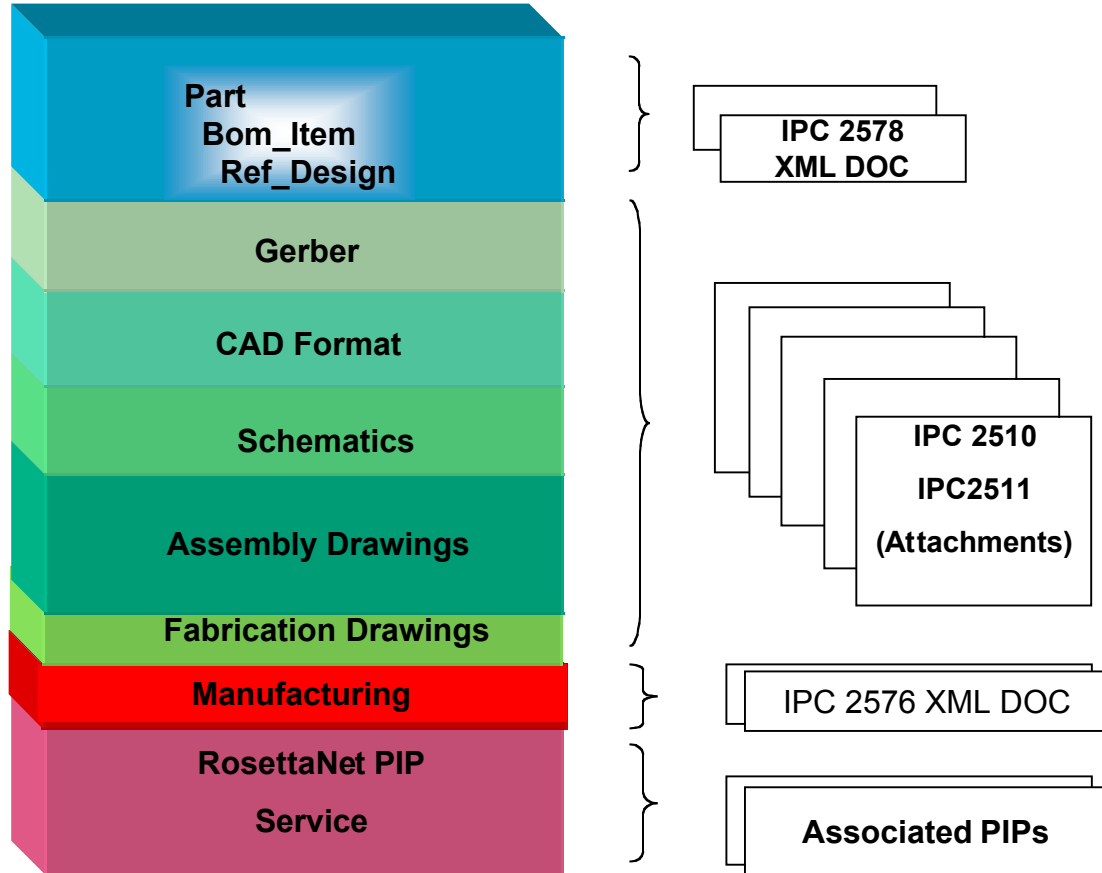



# “Virtual Factory” NEMI & RossetaNet Participation

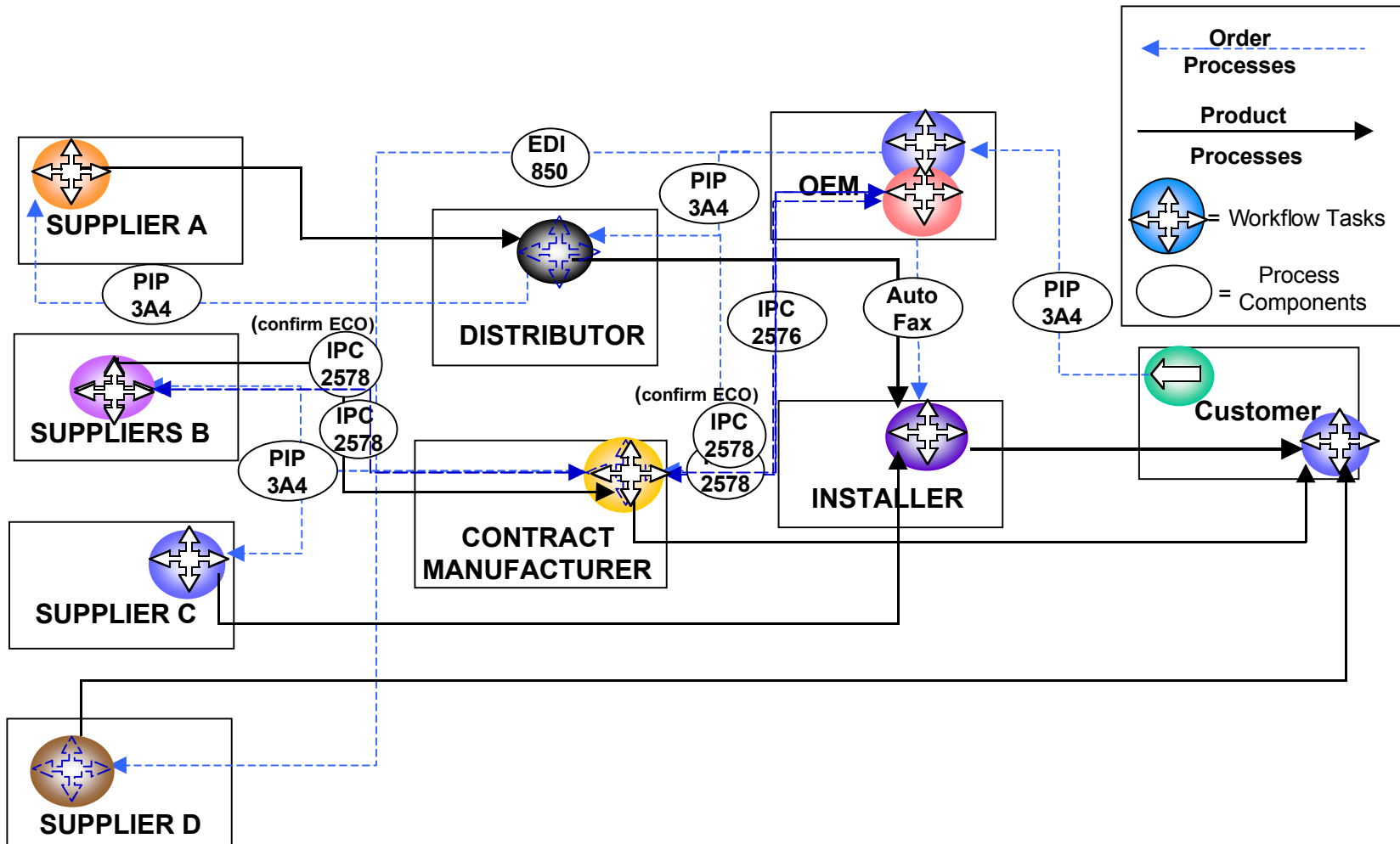



# SCI's Collaboration Platform

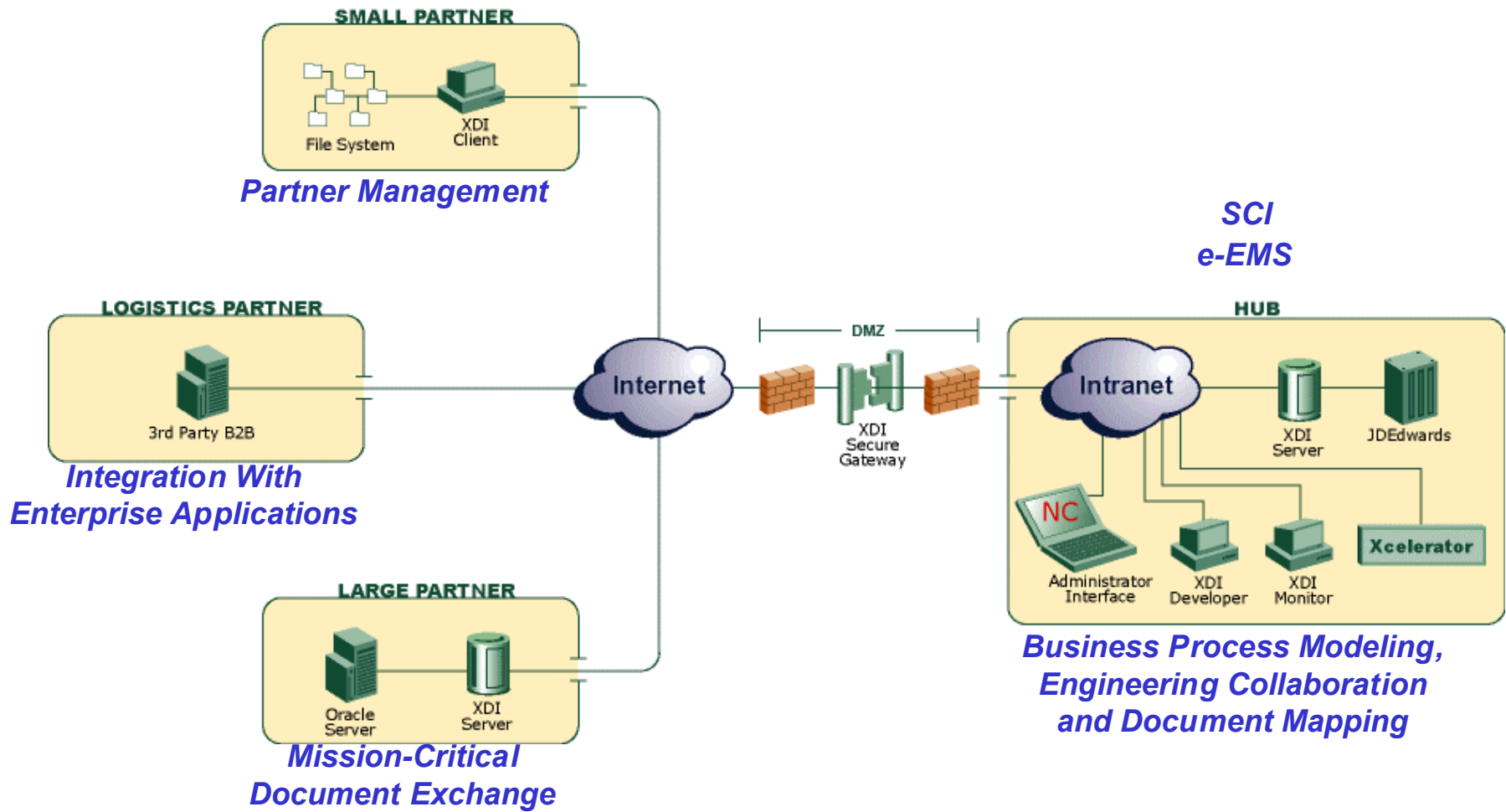



# SCI Process Hub

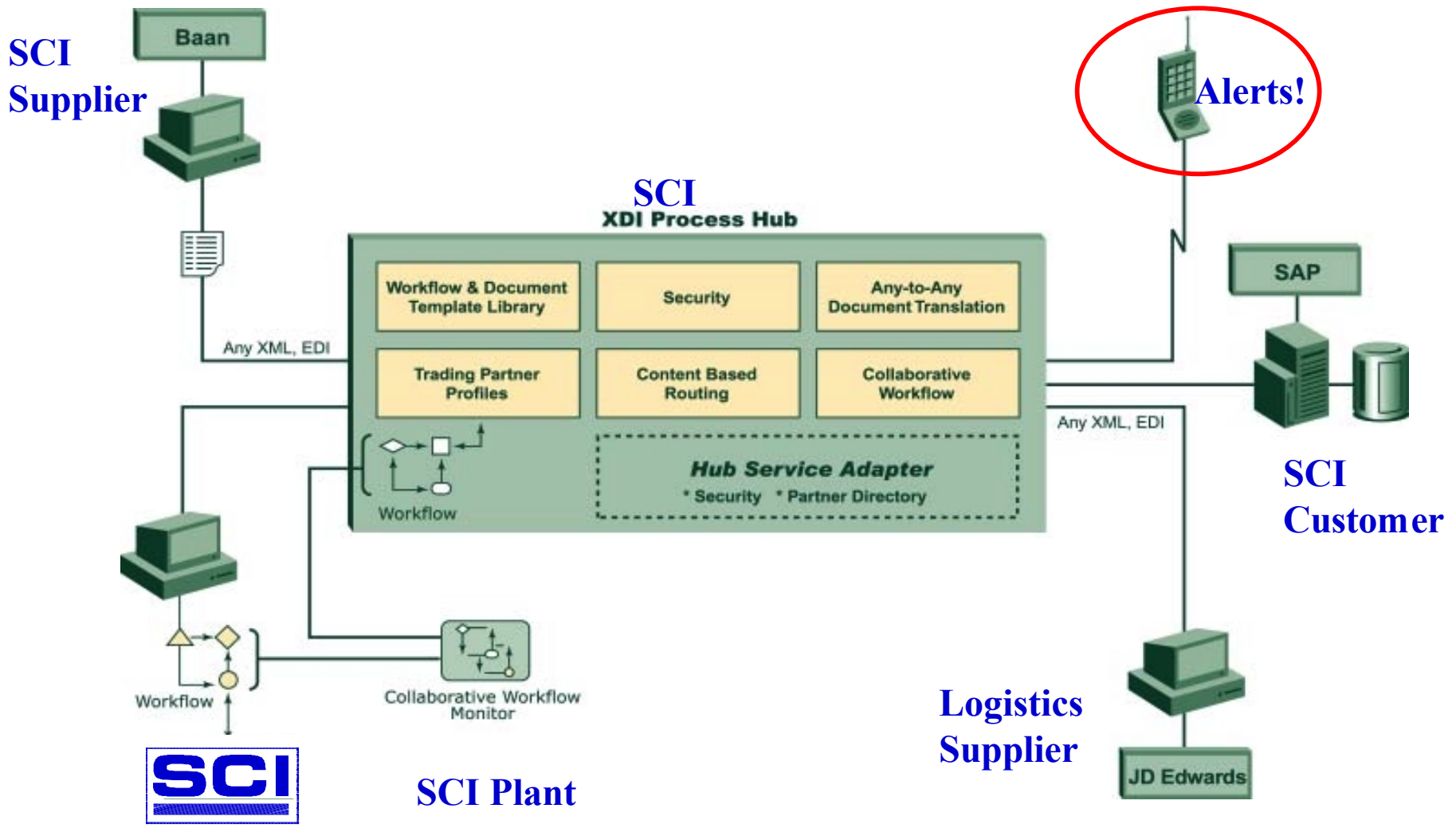



# XML eProcess Security

